



ENERGY CENTER
OF WISCONSIN

PREPARED BY
Energy Center of Wisconsin

with the assistance of

The University of Wisconsin
Solar Energy Laboratory

Hybrid Ground-Source Heat Pump Installations:

Experiences, Improvements and Tools

June 30, 2011

ECW Report 262-1

Hybrid Ground-Source Heat Pump Installations:

Experiences, Improvements and Tools

June 30, 2011

Scott Hackel

Senior Project Manager, Energy Center of Wisconsin

Amanda Pertzborn

Research Assistant, University of Wisconsin Solar Energy Laboratory



455 Science Drive, Suite 200

Madison, WI 53711

608.238.4601

www.ecw.org

Energy Center of Wisconsin

Copyright © 2011 Energy Center of Wisconsin.
All rights reserved

This document was prepared as an account of work conducted by the Energy Center of Wisconsin for the U.S. Department of Energy, with support from Alliant Energy and Madison Gas and Electric. Neither the Energy Center, participants in the Energy Center, the organization(s) listed herein, nor any person on behalf of any of the organizations mentioned herein:

- (a) makes any warranty, expressed or implied, with respect to the use of any information, apparatus, method, or process disclosed in this document or that such use may not infringe privately owned rights; or
- (b) assumes any liability with respect to the use of, or damages resulting from the use of, any information, apparatus, method, or process disclosed in this document.

Project Manager

Scott Hackel

Acknowledgements

Energy Center of Wisconsin staff who contributed to this project include Dan Cautley, Scott Schuetter, Jenny Levin, and Paul Thoresen.

Contractor staff who contributed to this project include Amanda Pertzborn, Dr. Gregory Nellis, and Dr. Sanford Klein of the Solar Energy Laboratory.

The project also received generous assistance from Cary Smith (Sound Geothermal), Jerry Zupancic of Cashman Equipment, and the staffs of Clark County School District and Urban Land Interests.

TABLE OF CONTENTS

Report Summary 1

Introduction..... 3

 Background 3

 Objective 4

Literature Review 5

Data Collection 6

 Buildings Studied 6

 Monitoring 9

 Cashman and East CTA 9

 Tobacco Lofts 10

 Ground Properties..... 10

Modeling 11

 Hybrid Ground-Source System 11

 Ground Heat Exchanger 11

 Other System Components 12

 Controls..... 12

 Building Models 12

 Economics..... 14

Validation 15

 Ground Heat Exchanger Model..... 15

 Cashman System 16

 Tobacco Lofts System 18

 East CTA System 19

Economic And Other Assumptions 20

 Installed Costs 20

 Energy Rates and Other Inputs..... 22

Results 24

 Optimal System Sizing 24

 Pumping..... 27

 Cooling Tower Control..... 30

 Cooling Tower Control, For Precooling 33

Long-term Operation and Temperature Effects.....	33
Precooling	34
GHX and General Control	37
An Alternative To Heating Dominated Hybrids	38
Boiler Control in a Hybrid	39
Heat Pump Operation	40
Energy and Economic Analysis of Hybrid Approach	44
Relative Energy Consumption of Components	45
Life Cycle Cost Comparison	47
Economic Sensitivities.....	50
Emissions Analysis of Hybrid Approach.....	53
HYGCHP Tool.....	56
Conclusions and Future Work.....	57
Future Work	57
References.....	59
Appendices	62
Appendix A. Data Collected	62
Appendix B. HyGSHP Fact Sheet.....	63

REPORT SUMMARY

We have seen the potential for ground-source heat pump (GSHP, or “geothermal”) systems to significantly reduce energy consumption in commercial buildings in comparison to more conventional systems. An innovation to GSHPs, a hybrid ground-source heat pump system (HyGSHP, or hybrid) can dramatically decrease the first cost of GSHP systems by using conventional technology (such as a cooling tower or a boiler) to meet a portion of the peak heating or cooling load. We believe that the lower first cost of HyGSHP systems has the potential to increase the rate of deployment of ground-source systems, generating large aggregate savings. In order to provide some of the additional information that the design community may need to implement this more innovative approach, we’ve completed a study of three hybrid installations. This study aimed to establish the economic and environmental performance of the approach, as well as document some lessons learned and improvements in hybrid design. Additionally, we validated our computational model of the hybrid system and have made it available to the building design community for general use.

Our study began by collecting data from two cooling-dominated buildings and one heating-dominated building. The cooling dominated buildings, Cashman Equipment (office and service) and East CTA (vocational school), are in the Las Vegas area. The heating dominated building, Tobacco Lofts, is in Madison, Wisconsin. Energy consuming systems at all three buildings underwent extensive monitoring for a period of one year. Models were also built of all three projects, utilizing coupled eQUEST (for building loads) and TRNSYS (for HVAC plant) models. The models were used in analyzing economic and environmental impacts, as well as in establishing the benefit of further refinements to the systems. These models were first validated using collected data, both component by component and at the system scale; validation successfully showed the models matching actual system performance within reasonable design uncertainty.

Analysis using these models showed that in all three cases, the hybrid systems were cost effective. Energy savings from using HyGSHPs instead of conventional HVAC was significant, and nearly equaled that from a purely ground-source approach. But the first cost of the HyGSHP system was substantially less than the ground-source-only system in all cases. The result is an average rate of return for investing in hybrids (versus conventional HVAC) from the three cases of 10%. If the project teams had invested in additional GHX to go to a full GSHP system, the rate of return on the *additional* investment for the rest of the GHX would have averaged just 3%.

In addition to economic impacts, we were concerned with the energy and environmental impact of the hybrid approach. The most straightforward metric for these impacts is simply the level of CO₂ emissions. The hybrid approach saved as much or more CO₂ emissions (versus a conventional HVAC system) as the ground-source-only system; choosing to hybridize a system does not substantially degrade the environmental benefits of ground-source.

In addition to analyzing the performance of these systems, we collected a list of lessons that were learned about effective hybrid design and operation. We learned some of those lessons through observation and modeling of the systems; others were learned indirectly from the teams that designed and operated the three systems we studied. The following is a brief overview of those lessons, which others may apply to their own similar systems:

- ✓ Component sizing in a hybrid system is extremely important—take special care not to oversize the load that drives the GHX size. Use a sizing algorithm that optimizes the tower or boiler; use hourly—8760—loads as inputs to these tools if at all possible.
- ✓ Pumping uses a substantial amount of energy in a hybrid system. Design decisions should minimize pump sizes, but more importantly focus on part-load performance. For example, for central pumping include a part-load pump of a smaller size (~50%). Choose variable speed equipment wherever applicable, with a well-positioned dP sensor that is adjusted (post-occupancy) downward to allow for the lowest speed possible.
- ✓ Cooling towers or fluid coolers in a hybrid system should be variable speed with multiple towers ramping in speed together (not staged), and ramping down quickly enough to shut off shortly after substantial cooling. Post-occupancy adjustment of the control setpoints can reduce energy usage.
- ✓ If analysis indicates nighttime precooling with a cooling tower is appropriate, it should be operated carefully (precooling is a strategy in which the tower is operated during nighttime in cooling season to take advantage of low wet bulb temperatures and low electric rates). Precooling should be operated: for a short period of time (a few hours), right before morning startup, and at a lower fan speed. The goal of precooling does not necessarily have to be a balanced load on the ground.
- ✓ The working fluid should be able to bypass the GHX. Set a reasonably wide deadband (20-30°F) in which the GHX is not used; turn on GHX in cooling-dominated systems only 7-10°F below the setpoint of the cooling tower.
- ✓ Boilers in hybrid systems should be placed downstream of GHXs, and controlled to a setpoint 5-10°F below the GHX. Condensing boilers work very well in these systems.

In addition to these results, we have made both the collected data and our validated hybrid system model (under the name *HyGCHP*) freely available on the Energy Center website, to assist in feasibility studies, design, and additional research. Both can be accessed at www.ecw.org/hybrid.

These lessons and tools can be used to help owners who would normally not consider a ground-source system to reconsider; the lower cost of the hybrid approach is certainly worth a pause in any system selection discussion. System complexity may still be an issue for some—depending on staffing, hybrids may not be the best choice for facilities without either an on-site HVAC facility manager or a good service relationship with a local mechanical firm. But in general, these systems should be both implementable and effective on most heating- or cooling-dominated buildings.

INTRODUCTION

BACKGROUND

Ground-source heat pump (GSHP, or geothermal heat pump) systems have shown potential to significantly reduce energy consumption in commercial buildings in comparison to more conventional systems. Yet ground-source systems have only been able to capture a few percent of the heating and cooling market due primarily to the prohibitively high cost of installing the necessary ground heat exchanger (GHX), which can cost an extra \$5/ft² or more (a 20-30% increase in HVAC cost). Hybrid ground-source heat pump (HyGSHP, or simply ‘hybrid’) systems are an innovative version of GSHPs; they build on GSHP systems by utilizing conventional technology such as a cooling tower or boiler to meet a portion of the peak heating or cooling load in the ‘geothermal’ loop (see Figure 1). With conventional equipment displacing a portion of an otherwise expensive ground heat exchanger, HyGSHP systems have the potential to make GSHP systems substantially more cost effective. This would likely increase the rate of deployment of ground-source systems in general. And though they are not *always* more efficient than ground-source only systems, hybrid systems’ ability to increase deployment of ground-source in general may create larger savings in aggregate.

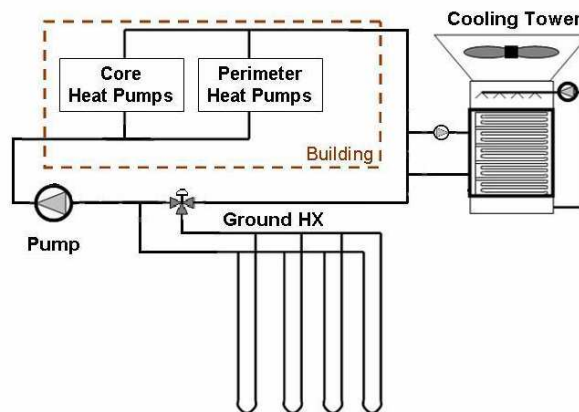

Figure 1. A hybrid ground-source heat pump system in a warm climate.

But HyGSHP systems have technical challenges that have slowed their growth initially. Adding the additional piece to the heating/cooling plant introduces complexity. Therefore there remains a lack of knowledge beyond all but the basic design principles—more information is needed in the market to improve designs, control systems, and general operation of the systems that exist and that will exist. If information is available and provided to owners and their facility staff, these systems can be operated quite successfully. Additionally, more data and tools need to be available for the engineering community to study hybrid systems. Tools that currently exist for modeling energy consumption, considering different design options, and conducting applied research all have difficulty with some area of hybrid systems.

OBJECTIVE

With this study we aim to provide some of that knowledge through analysis of three example sites in two different climates. Two sites were in the Las Vegas area—a hot and dry climate. The other site was in Madison (WI)—a cold, but humid (in the summer), climate. These sites proved most convenient and applicable for research given the availability and quality of data, and operational characteristics of the systems. This also allowed for study of both cooling and heating dominated systems; though many commercial buildings in Wisconsin are cooling-dominated, a multifamily building was chosen to ensure it would be dominated by heating loads. These buildings could therefore serve as “bookends” for applying lessons learned to a wider variety of other buildings.

We collected high resolution data at all of these sites for over a year with several goals in mind for using this data. First, we used it to validate models of hybrid components and systems that could be used not only by us but could be shared with others for improving research and design nationwide. Model validation included the DST ground heat exchanger (GHX) model in TRNSYS¹, a few other TRNSYS components, and a full hybrid module. The models are freely available to the public through the HyGCHP module². They can be used for further study of not only hybrid systems in general, but also feasibility and design studies of specific buildings being designed or retrofitted. We also used lessons learned in operation, costs, and equipment performance to improve the operation of the HyGCHP module.

Secondly, the validated models was used to demonstrate the effectiveness (or ineffectiveness) of the hybrid approach as compared with both conventional systems and ground-source-only systems. Effectiveness in this case is used as a descriptor of both cost effectiveness and environmental impact.

And thirdly, we used the data to identify lessons learned in the design and operation of the hybrid systems studied. This includes both lessons learned by design and construction professionals, energy managers and other operators, and even some information for facility personnel. We’ve also identified future improvement potential and quantified this potential using our hybrid models.

Finally, the data collected from the three sites has been made public for others to use in continuing to research and improve HyGSHPs.

It is worth clarifying one overarching point about these objectives. They are primarily focused on improving the *economic* effectiveness of heating, cooling, and ventilation (HVAC) systems. And while the holistic, life-cycle economics used here generally favors saving energy, sometimes economic optimization comes at the price of—often minimal—increases in energy consumption. If economics are not the key concern, and a builder or owner has the funding to maximize energy savings at any cost (rarely the case), the best practices may look somewhat different than those concluded in this report. However, if economics are optimized, than GSHP technology can be implemented in even more buildings, saving more energy in the aggregate.

¹ TRNSYS, or Transient System Simulation, is the energy modeling tool used to model the HyGSHP systems throughout our work.

² Originally begun under separate funding from the American Society of Heating, Refrigeration, and Air Conditioning Engineers, or ASHRAE. Our current model builds on the methods and components of that previous model, which was developed under ASHRAE research project #1384 (Hackel, 2009a).

LITERATURE REVIEW

Though there is still a great need for knowledge in the area of hybrid systems, there has been some excellent research already conducted on the subject. Several studies have presented the details of installation and operation of actual hybrid systems, generally in a case study format, with some lessons learned (for example, Wrobel, 2004; Phetteplace and Sullivan, 1998; and others). Some studies have also used simulation tools to model (Chiasson et al., 2009, Thornton, 2005) and optimize hybrid systems that are not yet constructed. Gentry et al. created an HyGSHP model of an actual full (experimental) building system setup, and validated it with the data collected.

General methodologies for the design of HyGSHP systems have been discussed by Kavanaugh (1998), Xu (2007), and others. Some studies have also focused on identifying effective control strategies for hybrids. One study was done by Yavuzturk and Spitler (2000), who identified an economical method of controlling a cooling-dominated hybrid system without adjusting the size of the equipment. The same conclusion on control methodology was reached in the Fort Polk study (Thornton, 2005), in which several differing control strategies were optimized and then compared. These studies have focused primarily on the design of cooling-dominated systems. However, some research has also been done relative to the design of hybrid systems for heating-dominated buildings; primarily using solar collectors as the supplemental device (Chiasson and Yavuzturk, 2003; Ozgener and Hepbasli, 2004; Chiasson, 2009).

Additional research has focused just on the modeling of the GHX component (one of a few *key* components) of these and other GSHP systems. There are dozens of computational models available for modeling GHXs (for a survey, see Yang et al. 2010). Our project relies on an adaptation of the GHX model developed at the University of Lund (Hellström, 1989), also known as the duct ground heat storage model (DST), which has been implemented in TRNSYS (Klein, 2006).

Our research builds on these previous works by focusing on data and lessons learned from actual hybrid installations, to both fully account for the challenges of implementing and operating a complex system in a real building, and to study the ability to improve these systems. It also uses this detailed data to validate models for more accurate analysis, as well as eventual dissemination as tools for the engineering community.

DATA COLLECTION

BUILDINGS STUDIED

Three sites in two different locations were selected for this study. Two cooling dominated hybrid ground-source systems were selected. Both are in the Las Vegas area—a hot, dry climate. The other site was a heating dominated system, and was located in Madison (WI)—a cold, humid climate. Of a dozen or so hybrid installations we considered, these sites proved most applicable for research given the availability and quality of data, and reasonably typical operational characteristics of the systems. Both cooling and heating dominated systems were selected so that they could serve as “bookends” for applying the lessons that we learned to a wide variety of other buildings.

The three buildings and systems are summarized in Table 1.

	Cashman	East CTA	Tobacco Lofts
Full Name	Cashman Equipment	East Career and Technical Academy	Tobacco Lofts at Findorff Yards
Building Type	An even mix of office, maintenance, and warehouse	High school	Multifamily (with minimal common space)
Location	Henderson, NV	Las Vegas, NV	Madison, WI
Area	305,000 ft ²	251,000 ft ²	74,300 ft ²
Area with GSHPs	205,000 ft ²	251,000 ft ²	57,200 ft ²
Year built	2008	2008	Built in 1899, Remodeled in 2005
Construction	Tilt-up concrete construction, built-up roof, double-pane tinted curtain-wall and storefront glazing, plus large glazed overhead doors in garage areas.	Tilt-up concrete construction, built-up roof, double-pane tinted curtain-wall and storefront glazing.	Structural brick, some furred-out insulation, built-up roof. Double-pane windows.
HVAC Configuration	Distributed HPs, with dedicated outdoor air	Distributed HPs	HPs in each unit, with dedicated outdoor air
GHX Size	360 bores, 400 ft deep	420 bores, 400 ft deep	39 bores, 280 ft deep
Supplemental Device	2x 250 ton closed-circuit cooling towers	2x 167 ton closed circuit cooling towers	199 MBH boiler
Supplemental Config.	In series, downstream of GHX	In series, downstream of GHX	In series, downstream of GHX
Pumping	Primary/secondary, constant speed GHX and variable speed building	Primary/secondary, constant speed GHX and variable speed building	Primary/secondary, constant speed GHX and constant speed building

Table 1. Data collection sites.

Cashman Equipment (Cashman) is a large equipment dealer in Henderson, NV (just southeast of Las Vegas). The campus is made up of seven buildings of multiple types, primarily offices, maintenance garages, and a warehouse. Roughly two-thirds of the campus is served by the HyGSHP system, which is connected via two variable flow campus loops back to a central mechanical room (the one-third of the campus not on HyGSHP is made up of the garages, which are on individual air handlers). A dedicated outdoor air system provides energy recovery and ventilation to each space, and is also on the HyGSHP

loop. The secondary building loops are served by a large primary loop, which has both GHXs and cooling towers attached. The GHX is divided into four independently pumped (constant speed) fields. The fields are divided primarily to keep equipment sizes smaller and make purging easier. The two towers are variable-speed (on fans) closed-circuit cooling towers (i.e. fluid coolers), pumped independently from the primary loop. A system schematic is shown in Figure 2; the primary loop is to the left, with the arrow showing flow direction. In this system, the GHX attempts to keep the loop temperature within a set temperature range; if the upper setpoint cannot be met by the GHX, the cooling towers both ramp up in speed to meet the setpoint. An image of the buildings is shown in Figure 3.

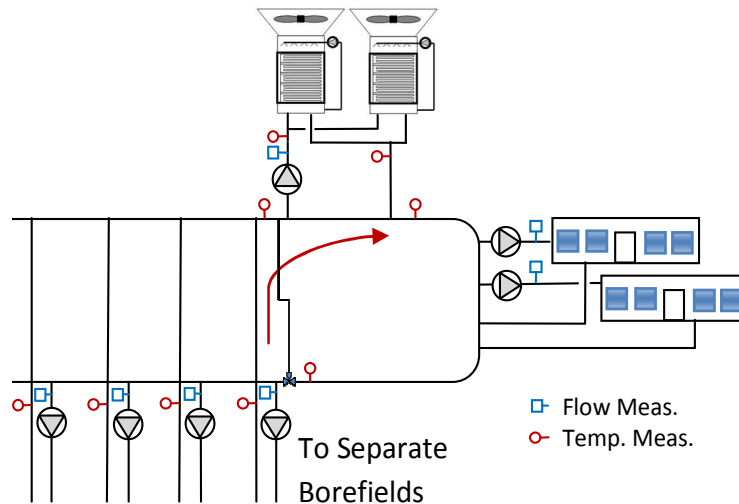

Figure 2. System schematic for Cashman. East CTA had a very similar configuration, but only used one building loop (instead of two), had seven GHX loops (instead of four), and did not include GHX bypass.



Figure 3. One of the buildings on the Cashman Equipment campus.

East Career and Technical Academy (East CTA) is a vocational high school in Las Vegas, NV. The school is divided into several different areas, each providing education in a different vocation—from auto repair to culinary arts. Much of the space is typical of a high school (offices, hallways, classrooms, etc.) but the vocational nature of the school means that there are also large workshops, a full commercial kitchen, and other specific process loads and spaces. These diverse spaces are all served by a HyGSHP system. Individual, closet-installed heat pumps serve each space (with large spaces served by 2-3 heat pumps) and are tied back to the mechanical room via one large variable flow secondary loop. These

secondary building loops are connected to a primary loop, which has both GHXs and cooling towers attached. The GHX is divided into seven independently pumped (constant speed) fields. The fields are divided primarily to keep pump and piping sizes smaller, and make purging easier. The towers are two-speed closed-circuit cooling towers (i.e. fluid coolers), pumped independently from the primary loop (with variable speed pumps). The system is similar to Cashman's (Figure 2), but with seven GHX circuits, one building loop, and no GHX bypass. A picture of East CTA is shown in Figure 4.



Figure 4. One of the buildings on the East CTA campus.

The Tobacco Lofts at Findorff Yards (Tobacco Lofts) is a multifamily building in Madison, WI (originally warehouses built in 1899). The Lofts are composed of two buildings (East and West) with 61 individual one or two bedroom living units, and one small office suite. A parking garage also occupies one floor of the West building. All the residential units, entryways, and the office are served by the HyGSHP system (the hallways—including building ventilation—and garage are served by unit heating equipment), which is connected via a variable flow³ loop back to a central mechanical room. This loop has both a GHX and boiler attached to it. The GHX is made up of four circuits, all pumped using one constant speed pump. The boiler is a fully modulating condensing boiler, with its own constant speed circulation pump. A system schematic is shown in Figure 5. In this system, the GHX runs continuously to meet heating/cooling loads, and the boiler is turned on—fairly infrequently—only if the lower setpoint cannot be met by the GHX. Figure 6 shows a picture of the Tobacco Lofts.

³ The system was designed as variable flow, but issues with the variable frequency drives now cause it to run at constant speed. This was true during much of our data collection period, but is currently being dealt with by facility staff.

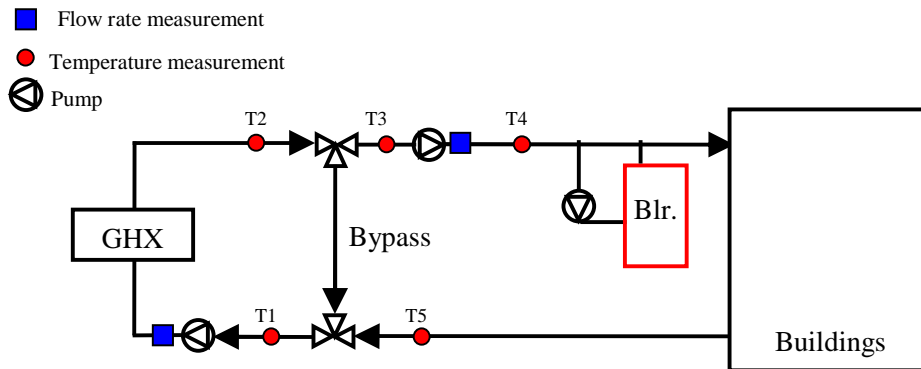

Figure 5. Schematic of the system at Tobacco Lofts.



Figure 6. One of two Tobacco Lofts buildings.

MONITORING

Cashman and East CTA

At both Cashman and East CTA, the building automation system (BAS) was used for data collection. At these facilities the BAS monitored key parameters at 15-minute intervals (with instantaneous measurements). These parameters included submetered energy consumption (a calibrated meter for each panel), loop temperatures at all key points (as shown in Figure 2), all loop flowrates, and equipment on/off status. Additionally, some key building operational parameters such as ventilation and lighting status, were collected at both sites. At both of these sites, monitoring was set up relatively quickly after the buildings were occupied, and data represented the initial, post-commissioning operation of the system (though some commissioning issues are still being addressed at East CTA).

Temperature measurement through the BAS at these sites is assumed to have an uncertainty of $\pm 1 \Delta^\circ\text{F}$. This results in the uncertainty of temperature *change* being $\pm 1.3 \Delta^\circ\text{F}^4$. Flow rates at Cashman were measured using inserted turbine flowmeters. These meters (Onicon F-1210 and F-1110) have a manufacturer specified uncertainty of at most 2% of full scale. At East CTA, flow rate was simply based

⁴ Temperature change is directly proportional to heat flow, and is therefore the more important uncertainty in this project; see Pertzborn (Pertzborn, 2011) for a more in depth discussion of measurement uncertainty on this project.

on spot flow measurements using ultrasonic tools, matched to pump speed. Temperature and flow measurements at both Cashman and East CTA were further validated using energy balances. The full year of data from both Cashman and East CTA is available for others to use for research and/or comparison purposes (see *Appendix A. Data Collected*, in the *Appendices*).

Tobacco Lofts

Tobacco Lofts did not have an extensive BAS. Instead, data collection equipment was custom installed for this project. Temperatures at all points (as shown in Figure 5) were collected using calibrated thermocouples inserted in wells, with an estimated uncertainty of only $\pm 0.4 \Delta^\circ\text{F}$. Power consumption was measured using current transducers (with spot-metered voltage), and status of key pieces of equipment was collected, also with current transducers. Flow rate was measured in both the main building loop and GHX loop using balancing valve pressure-drops (using a Dwyer 629-01-CH) calibrated to ultrasonic flow measurements (and further validated with energy balances between loops). In addition, in six apartment units (10% of units), the heat pump power, temperature drop/rise, run-time, and return air temperature were collected at each heat pump. At this site, there were five years of operation before our study began, with significant effects on validation of the Tobacco Lofts model (see *Validation*).

An energy balance was performed on the bypass leg of the system using these temperatures and flow rates. Initially the energy entering and leaving the bypass did not balance within the uncertainty of the instruments; flow rate was determined to be the issue (the valves were not meant for research-grade measurements), so additional flow rate spot measurements were taken using a transit-time ultrasonic flow meter (Fuji FSCS10A1-00) with a manufacturer specified accuracy of $\pm 1\%$. The continuously monitored flow rates measured using the orifice were calibrated to match the flow rates measured from the ultrasonic flow meter; the result was a dramatic improvement in the bypass energy balance. Additional checks using a boiler energy balance and a calibrated building model yielded similarly good results.

The full year of data collected from Tobacco Lofts is available for others to use for research and/or comparison purposes (see *Appendix A. Data Collected*, in the *Appendices*).

GROUND PROPERTIES

One of the objectives of our study is to validate the models (and components of models) that were constructed (both for this analysis and public distribution). Validation of any ground-coupled system requires an independent empirical measurement of the ground properties. In this case we had independent in-situ thermal conductivity tests from all three sites studied. Results of these tests are shown in Table 2.

	Thermal Conductivity (Btu/hr-ft- $^\circ\text{F}$)	Thermal Diffusivity (ft ² /day)	Undisturbed Ground Temp. ($^\circ\text{F}$)	Date - TC Test	Date - GHX Startup	Date - Beginning of Study Data
Cashman	1.12	0.69	78.0	October 2006	November 2008	January 2009
East CTA	0.92	0.55	76.0	June 2006	August 2008	February 2010
Tobacco Lofts	2.02	1.24	53.5	July 2003	August 2005	January 2010

Table 2. Results of thermal conductivity tests at the three sites.

MODELING

One key objective of our research was to go beyond the actual operation of the building and compare its operation to other hypothetical design and control strategies, including conventional (non-GSHP) systems. Another objective required the development of validated models for use by the engineering community. These objectives required computational models of these systems to compliment the collected data. These models capture the full operation of the three systems, from the detailed heating and cooling loads on the buildings, to the operation of the hybrid systems to meet these loads, to the economic impacts of the installation and operation of the systems.

HYBRID GROUND-SOURCE SYSTEM

Models of the HyGSHP system were constructed in order to make meaningful, direct comparisons. The HyGSHP plants from each site were modeled in TRNSYS (TRansient SYstem Simulation) using both off-the-shelf and custom components. TRNSYS is a software tool composed of a library of components that are connected together to model transient systems (Klein and et al. 2006)⁵. The component models, which are described below, were configured according to each of the actual system installations as shown in Figure 2 and Figure 5 above.

Ground Heat Exchanger

The ground heat exchanger (GHX) considered in this analysis is a vertical GHX with U-tube piping. The thermal interaction between the fluid and the ground is simulated using the duct storage (DST) model of a vertical GHX field (Hellström 1989; Type 557a in TRNSYS). This model, which is one of the more widely recognized borefield models, was previously included as a TRNSYS component model. The DST model calculates the ground temperature using the superposition of three separate heat transfer calculations:

- a global solution accounting for heat flow away from the borehole over months or years,
- a local solution accounting for heat flow on shorter time scales near the bore hole,
- and a steady flux solution accounting for the slow redistribution of heat through the sub-regions near the bore hole.

The local and global solutions require implementation of a finite difference method while the steady flux solution is an analytical model. The combination of these three calculations accounts for the heat transfer between the fluid in the pipe and the ground near the pipe as well as the effect of neighboring bore holes on each other. Prior successful calibrations performed on this model have demonstrated its effectiveness (Thornton et al. 1997, Shonder et al. 1999; others). This project goes on to complete a validation specifically of this model component, based on comparison to entirely empirically gathered data at the sites studied.

⁵ The model utilized similar methods, including some component types, as the generic HyGCHP software module that was developed previously under an American Society of Heating, Refrigeration, and Air Conditioning Engineers (ASHRAE) research project (Hackel, 2009a; one goal of pursuing funding for this project was to validate the work done under that project).

Other System Components

COOLING TOWER

At Cashman and East CTA, a closed circuit cooling tower (CCCT, often called a fluid cooler) is used as a supplemental device. The CCCT component model (Type 510 in TRNSYS) is based on a simulation method developed by Zweifel et al (1995) to cover tower operation across a wide range of operating conditions. This type of cooling tower consists of a coil through which the heat transfer fluid flows; water is sprayed on the outside of the coil, leading to an energy transfer from the fluid stream to the atmosphere that is aided by evaporation. The fluid, now at a lower temperature, flows into the building loop to provide cooling. In this case the exiting fluid temperature is solved using a model developed by Zweifel (1995); in this reference Zweifel gives examples of successful comparison of this model to manufacturer data.

BOILER

At Site 3, a boiler is used as the supplemental device. The boiler model is based on manufacturer's data (using Type 659 from TRNSYS).

HEAT PUMPS

Heat pump performance is modeled using a model based on manufacturer's performance curves and rated efficiencies. The equations derived from these curves relate unit capacity, fluid flow rate, and efficiency. The model uses a modified version of Type 504 from TRNSYS; see Hackel (2009a) for details.

PIPING

The large amount of piping in a HyGSHP system requires modeling of at least its thermal capacitance. An input recall device (Type 93 in TRNSYS) is used in this case that simply stores the value of fluid temperature for one timestep. At 15 and 30 minute timesteps in these three systems (used in both our studies and the public distributable version of the model) our tests show that this produces accurate results with less computation than a full pipe heat transfer model.

Controls

Controls for the hybrid system are based on the actual control sequences used in the three buildings studied, coded as custom-built controls components in TRNSYS (modified minimally for TRNSYS capabilities). Descriptions of those sequences can be found in the *Buildings* section above; possible improvements to these control sequences are given in the *Results* section below.

BUILDING MODELS

In addition to the system models, we also constructed models of each building in eQUEST. The loads from eQUEST were used to drive simulations in TRNSYS; the heat pump coils served as the dividing line between the two softwares—this decoupled approach has been proven successful in other situations (Thornton, 2005, etc.). Building models were needed to 1) allow comparison of HyGSHP to other systems and climates, 2) create weather-normalized loads for the models, and 3) determine how the building is being used as compared to its design.

We calibrated the building models using extensive collected data so that the loads on the HyGSHP system accurately reflected those during the study period. This was especially important because the results of this study rely on a mix of conclusions based either solely on calculations of measurements or solely on simulation of hypothetical cases. Building models were calibrated primarily to match measured energy consumption of building components, especially each HVAC component (while the “plant” side in eQUEST was set up to provide measured temperatures during calibration). Secondly, and in support of the primary objective, schedules and operation were calibrated to the extent possible.

To ensure an appropriate, accurate calibration, our process followed the Measurement and Verification Guidelines: Measurement and Verification for Federal Energy Projects (FEMP, 2008). Per this guideline, the building models were created for each building using all the information available from a full set of construction documents, walk-throughs of each building, and interviews with staff. Actual weather data from the study period was gathered from local weather stations and used in the models. We then calibrated the models by varying the remaining model variables (infiltration, window u-value, occupancy, etc.) until energy consumption of the building model was within 15% of measured data each month, and annual energy consumption was within 10%, as required by the FEMP guideline. We were also able to come close to this quality of match for peak demand, as well as the annual breakdown of lighting, plug loads, and HVAC equipment, which was measured at all sites other than Tobacco Lofts. At Cashman, where the model is more complex, and more complex controls analysis was conducted (see results below), the comparison was taken further to obtain at least an approximate match of hourly trends on typical days including lighting, HVAC unit operation, and plug loads. Once calibrated, these models were used to produce loads which were used extensively for analysis of the HyGSHP systems using the TRNSYS models.

In addition, we converted the building models to use more conventional HVAC system types for the economic and emissions comparisons between HyGSHP, GSHP and “conventional” systems. The conventional system assumed for the two cooling dominated buildings in Nevada was a hydronic VAV system (with boilers and chillers). The conventional system assumed for the heating dominated building in Madison was a water-source heat pump system. These represent the more conventional approaches considered by the owners and design teams in each case⁶. Of course these systems could not be modeled with our ground-source heat pump model; hence the revised eQUEST models were used but carefully compared, component by component, to the TRNSYS models. The conventional systems were modeled based on ASHRAE 90.1-2004 (the reigning energy standard when they were designed), with some improvements.

⁶ A more common conventional system in Wisconsin for many multifamily buildings might be considered a packaged air conditioning unit (with gas fired heat). This is not feasible in all multifamily buildings, and was not a feasible option for Tobacco Lofts due to historical, aesthetic, and special issues. cursory analysis shows that these packaged systems are approximately as efficient as a water-source heat pump system, depending very heavily on the ratio of the price of natural gas to electricity (for much higher natural gas prices, the water-source heat pump is more cost effective; for lower natural gas prices, the packaged system is more effective).

Improvements were made to recognize that the design teams in each case were willing to make some highly cost-effective improvements even if a ground-source system couldn't be achieved. These included:

Boilers:	Tobacco Lofts: 93% efficient condensing boilers Las Vegas buildings: 83% efficient forced draft boilers
Duct and fan design:	15% improvement in fan power required, for all buildings
Energy recovery:	Tobacco Lofts: same DOAS with energy recovery as in HyGSHP case
All non-HVAC components:	Modeled as-built; identical to the ground-source simulations (including lighting, envelope, etc.)

ECONOMICS

Economic models were built in basic spreadsheets to consider a wide array of economic factors and scenarios. Pieces of these models were also constructed in TRNSYS to facilitate life-cycle cost optimization of these systems within the TRNSYS environment. All economic models relied on federal life-cycle costing principles, as discussed later.

VALIDATION

To create confidence in the results of the hybrid component and system models, both for this and future applications (including the distributable version of the model) the models were validated. Validation began with key individual components, and transitioned to full system validation.

GROUND HEAT EXCHANGER MODEL

The key component in all three systems studied is the GHX—it has the highest first cost of any component, and transfers a large majority of the energy in the system. Prior calibrations performed on the DST model had demonstrated its effectiveness (Shonder et al, 1999; Thornton et al, 1997); in those studies the ground properties in the GHX were calibrated in order to achieve the best match between the modeled heat pump entering water temperature ($T_{HP,in}$) and the measured $T_{HP,in}$. Our study utilizes independent in-situ measurements of all ground properties in addition to empirical performance data (see the *Monitoring* section) to allow for an indication of the quality of the results from the DST model as compared to independent measurement.

For Cashman, validation was completed four separate times, once for each of four borefields. Change in temperature (ΔT) across the GHX was used as a metric, with flow and input temperature used as inputs. Prior to comparison with measured data, the measured data had to be cleaned of instances ramping flow. Ramping flow was problematic because the instantaneous data collection at Cashman didn't allow us to characterize what was occurring during times when pumps were ramping up and down (luckily such transition periods were infrequent in Cashman's operation). For the resulting data set, modeled temperature change followed measured temperature very closely, and error was both within the uncertainty of the temperature measurement, and within the range of what is acceptable to a designer of GSHP systems. Specifically, mean bias error (MBE; a measurement of the average error across all data points⁷) for this comparison averaged 0.23°F across the four fields. An example of the quality of the match is shown in Figure 7 for one of the fields. The MBE for each of the four fields is shown in Table 3.

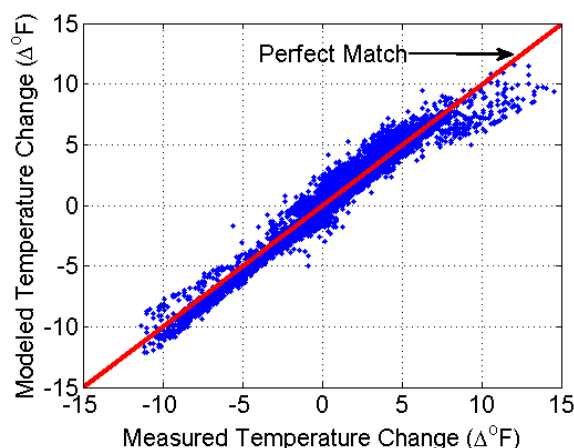

Figure 7. Modeled temperature change versus measured temperature change, across Field #4.

⁷ $MBE = \frac{\sum (Modeled - Measured)}{N}$

Error for Modeling of four GHX Fields at Cashman	
	MBE (ΔF)
Field 1	0.32
Field 2	0.16
Field 3	0.29
Field 4	0.11

Table 3. Mean bias error for each of the four GHX fields measured at the Cashman site, as compared with DST modeling.

This validation was also performed at the Tobacco Lofts. Here, the initial comparison as performed above resulted in a plot with very little scatter, but a slope closer to 0.7 than 1.0—meaning that the model was overpredicting GHX performance significantly. The MBE was 0.9°F; somewhat large in comparison to measurement uncertainty (though possibly still reasonable for some design purposes). There are a few reasons—other than an inaccurate model, which is unlikely due to the lack of scatter—that the model is overpredicting performance. First, there was a substantial seven-year lag between the thermal conductivity test (of a single bore) and the initiation of this study. It is possible that the test was performed at a time and place with abnormally high ground water flow or some other localized phenomenon affecting thermal properties⁸. There are also factors in the installation of the system that can lead to abnormal performance; the most likely causes being a flow imbalance and/or voids in the grouting of the u-tube (both leading to reduced heat transfer). Finally, in the five years of operation of the GHX, it is possible that some phenomenon has changed the thermal properties of the ground somewhat (research into long-term changes of GHXs is still in its infancy; there is little for us to lean on in this regard).

To account for this, the ground properties were calibrated, to see what the effect would be on the match. The calibrated conductivity was 60% of the measured value and resulted in a decrease in MBE to just 0.2°F (see Table 4). But note that in both the ‘Measured’ and ‘Calibrated’ property cases, the modeled values follow the measurements closely (as shown in the system validation, Figure 9). It is most likely that one of the phenomena described above is causing the larger error shown in the ‘Measured Values’ case, as opposed to a model that is inaccurate to a level of 40%.

	Conductivity (Btu/h-ft-F)	Heat Capacity (Btu/h- ft ³ -F)	MBE (ΔF)
Measured Values	2.02	39	0.9
Calibrated	1.20	24	0.2

Table 4. Ground properties used in the model and the resulting MBE when compared with measurements.

A much more detailed explanation of the full GHX validation effort is described by Pertzborn (2011).

CASHMAN SYSTEM

Prior to completing a full system validation for the Cashman system, a couple other component models were validated individually. The closed-circuit cooling tower is another key component in the system to

⁸ High groundwater flow is very likely at this site, when considering the local hydrogeology and abundance of groundwater, and the fact that the tested conductivity value is at the very high end of published values for sandstone.

validate. At Cashman, there are two cooling towers in parallel; both were validated simultaneously. Temperature change across the device was again used as a metric, with input temperature and flow rate based on measured results. The mean bias error of the comparison (in Figure 8) was 1.3°F; somewhat higher than that in the GHX, but still acceptable for a model used for either design or the type of economic analysis being considered here.

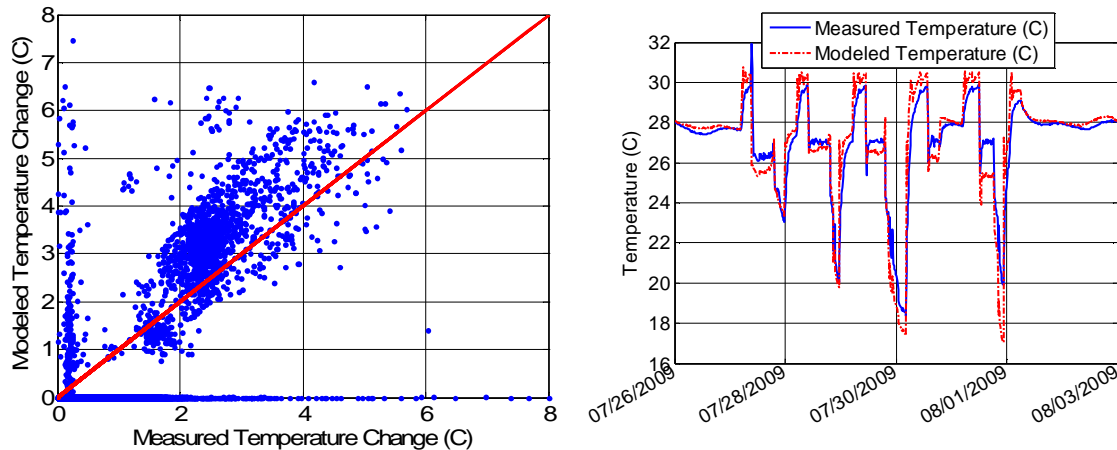

Figure 8. (a) Modeled temperature change across the cooling towers versus measured and (b) the same data plotted vs. time for one specific week in mid-summer.

Based on prior validation studies (Zweifel, 1995), the cooling tower model was expected to reproduce the measured results with better accuracy. One cause of the disagreement is that prior studies focused on comparing the model to manufacturer data rather than field data. Manufacturer data do not account for sub-optimal operational factors such as fouling and therefore over-prediction of the actual performance is not surprising. In addition, as in the case of the DST model validation, the use of instantaneously measured data leads to at least some error: the fan speed is measured instantaneously every 15 minutes, and those measurements are used across an entire 15 minute timestep (rather than using any averaging). The air flow, therefore, is generally greater in the model than it is in reality and the heat transfer is over-predicted (the towers ramp up quickly, so they spend most of their time ramping down).

The piping in the system also requires some attention. To allow us to complete a broad range of analyses, we were hoping to be able to effectively model a system with 15-30 minute timesteps; in this timeframe the piping (and the fluid it contains) could provide significant thermal capacitance. Capacitance was modeled using various estimates for the size of the piping and the fluid contained, as well as one simplified approach that assumes capacitance is always equal to the amount of fluid that flows through the heat pumps in one timestep⁹. In this case, all of these methods resulted in essentially identical results. The simplified approach was therefore used in the model.

With key components validated, we connected the components and modeled the hybrid system, with controllers being used to mimic the control sequence of the system as closely as possible. We used $T_{HP,in}$ as the performance metric. For Cashman, the model included all borefields, fluid coolers, piping, pumps,

⁹ Called 'Input Recall' in TRNSYS.

and all other associated distribution equipment. Figure 9 shows the results of this validation; the modeled $T_{HP,in}$ follows the measured value closely, with an error of less than 2°F at the peaks. Note the one week in plot (c) in which the modeled temperatures stop following the measured data; this is a good example of the difficulty of using the model to exactly match the control sequence used at Cashman .

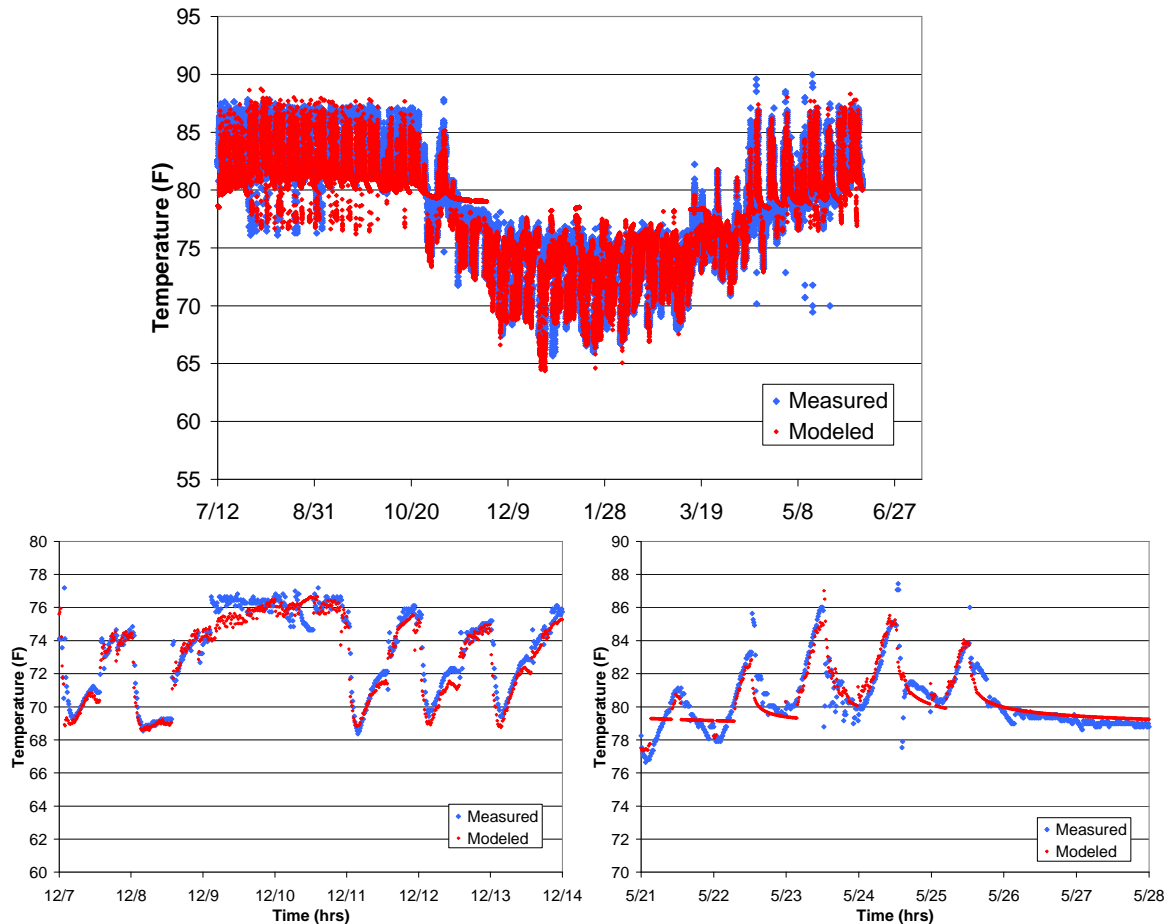

Figure 9. System validation results for Cashman for three different time spans: (a) a broad span covering heating, transition, and cooling, (b) a week during the heating and (c) a week during the cooling season.

The heat pumps themselves were outside the scope of the Cashman validation. The lumped heat pump model being used is basically a tool to calculate the COP of transferring heat between building and loop loads, based on curves for water and air temperature. There is no need for consideration of individual heat pump size or instantaneous capacity. As this and other research shows, there is large variation just between operating performance of different—but supposedly identical—units, as well as between those performances and AHRI ratings (see *Heat Pump Operation* below). Attempting accuracy beyond that of using rated COP for this level of modeling is therefore not useful.

TOBACCO LOFTS SYSTEM

Validation of the Tobacco Lofts full system proceeded similarly to that of the Cashman system. This was done using the loads in the building as the only input, and so included the heat pump model in this

instance¹⁰. The results of this validation are shown in Figure 10(a-c); we tracked $T_{HP,in}$ closely to measured values throughout the year, with error of similar magnitude to the Cashman case.

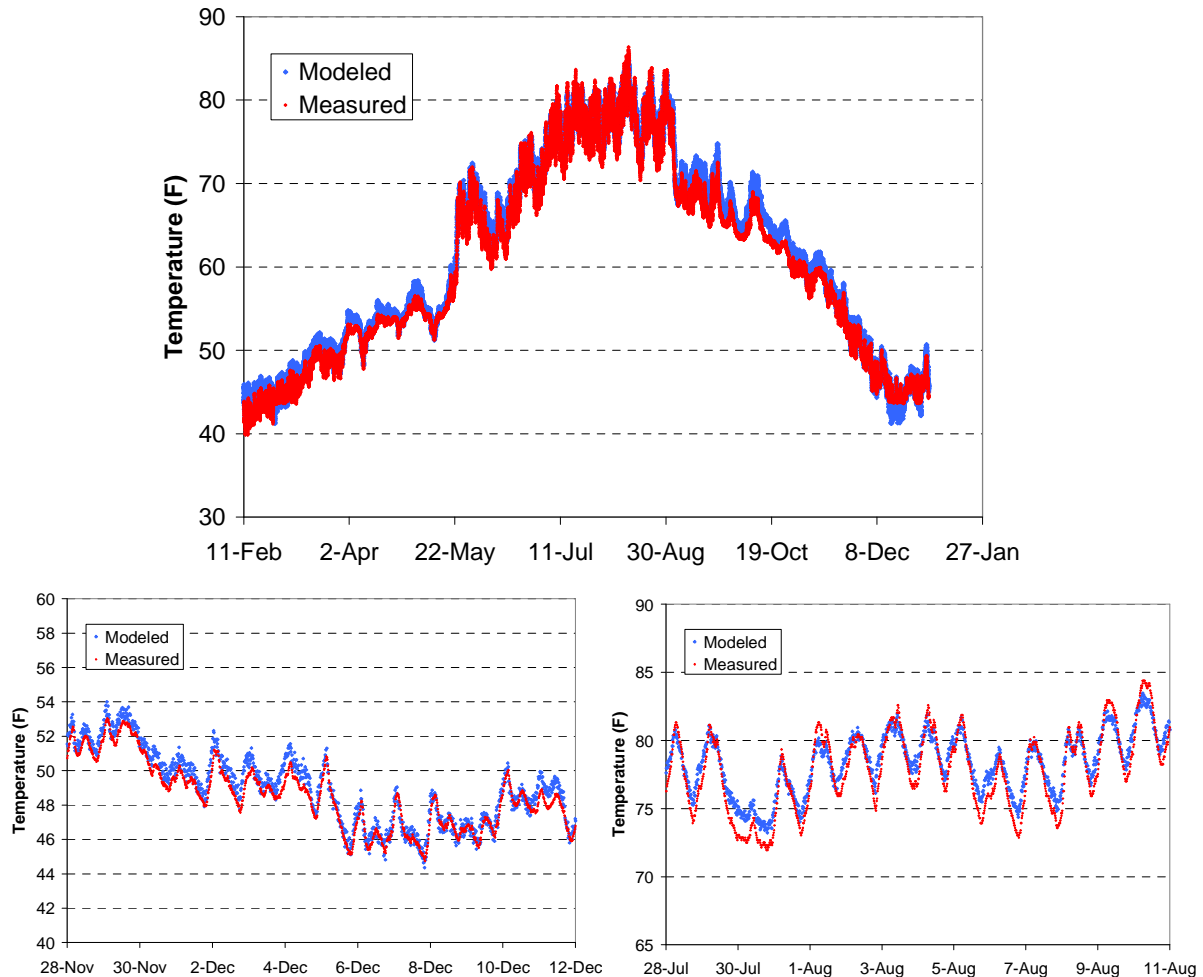

Figure 10. System validation results for Tobacco Lofts for two different time spans: (a) a span covering heating, transition, and cooling, and (b) a week during heating and (c) a week during cooling season.

EAST CTA SYSTEM

Issues with data collection at East CTA pushed the timing of this data beyond that of our validation work. Therefore East CTA was not included in validation efforts.

With our models validated to a reasonable extent (some at the component level, and all pieces at the system level), both components and models can be used for broader studies of these systems. These models (in the form of the HyGCHP distributable) can also be freely used by the public for further general research or study of system designs for specific buildings.

¹⁰ The GHX in this model was simulated based on calibrated properties; see the *Ground Heat Exchanger Model* section above for a discussion of those properties and why we are considering them here.

ECONOMIC AND OTHER ASSUMPTIONS

As technically complex as the operation of hybrid systems is, one of the largest challenges in making conclusions about optimal design and control is the *economic* input that is required, specifically cost information (cost data is notoriously difficult to compile for building components). Therefore we made gathering cost data a specific task for this project. We started by assuming that the most relevant analysis for this study would be one that considers a hypothetical decision that needs to be made in the present—therefore our analyses use 2010-dollar costs and current economic data, current emission rates, and average weather (as opposed to using costs at construction time, historical weather from that year, etc.).

INSTALLED COSTS

Installed costs for the full HVAC systems were based primarily on bid costs observed in the actual areas where the three installations are located (including the bid costs for the actual facilities studied). GHX costs are used along with other unit costs in optimizing the systems, as well as in scaling costs between HyGSHP and GSHP systems. Those costs are given in Table 5.

<u>Las Vegas Area</u>	
HyGSHP system incremental to conventional hydronic VAV (\$/ft ²)	3.9
Installed GHX costs (\$ / installed foot of bore)	11.9
<u>Madison Area</u>	
HyGSHP system incremental to conventional WSHP system (\$/ft ²)	3.6
Installed GHX costs (\$ / installed foot of bore)	15.6

Table 5. Installed cost assumptions for economic analysis.

Economic sensitivities were then done considering the effect of other costs observed nationally. The sensitivity data were compiled from a large range of sources, including the sites themselves, other recently recorded projects, recent surveys of system cost for various applied research projects (including Michaels, 2008 and Hackel, 2009b), and a collection of cost data currently being compiled by Dr. Kavanaugh (pers. correspondence, 2010). This cost data is plotted in Figure 11 for full system costs and in Figure 12 for just GHX costs. Each point plotted represents a cost recorded for one project; these points are simply plotted in order of increasing cost.

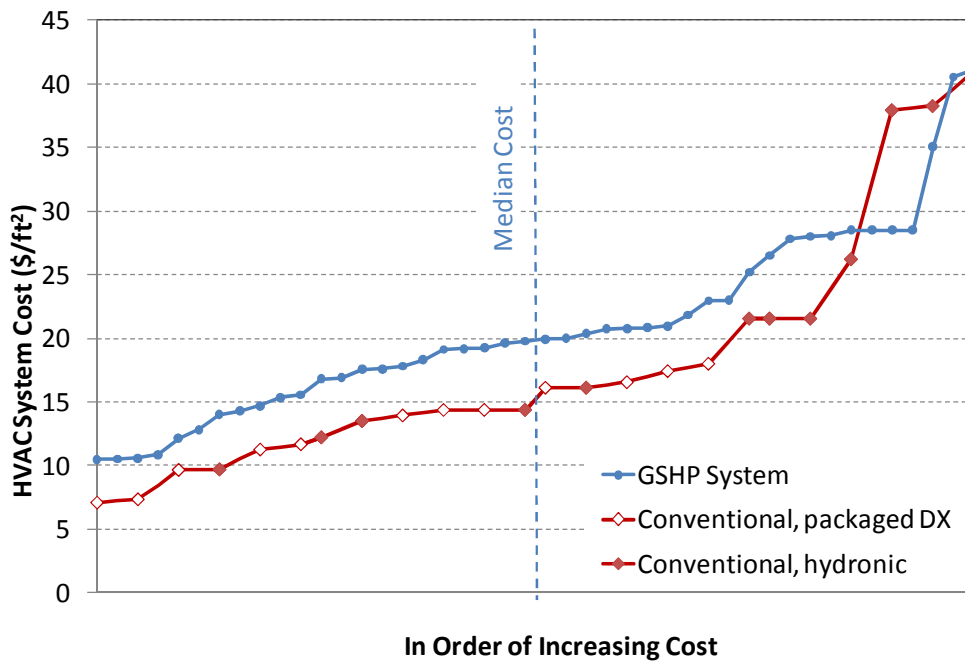

Figure 11. Nationwide cost data for conventional and GSHP systems, plotted in order from lowest to highest cost.

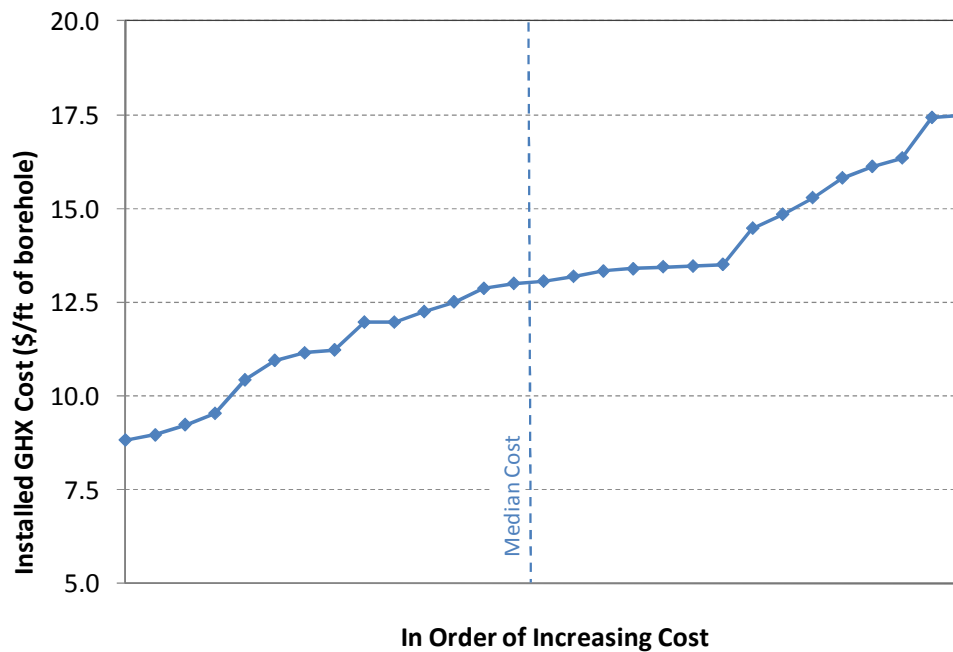

Figure 12. Nationwide cost data for GHX installation, plotted in order from lowest to highest cost.

Of course every building and site is different (different labor rates, system complexity, etc.), and that leads to the large range of different HVAC costs across projects. Therefore this is not a large enough data set to use for the purposes of fundamental market research, but it is useful for the economic comparison being done here. Any single set of points between these two lines should not be compared (as they are not

necessarily from the same building), but at a higher level it is worth noting the relatively constant incremental cost between conventional systems and GSHP systems, on the same order of magnitude as the \$4 incremental cost identified for the Las Vegas and Madison buildings.

We also needed costs for supplemental equipment. Sufficient data for each location was not available. Instead, costs for each supplemental device were based on average costs from a mix of RS Means mechanical cost data and installation costs from at least three similar equipment installations. The cost data for heat pumps includes materials and labor for the unit installation. The cost data for boilers and cooling towers includes materials and labor for the device plus all piping and valves directly serving the device.

Boiler (\$/MBH)	21.7
Cooling tower (\$/ton)	252
Heat pumps (\$/ton)	1380

Table 6. Supplemental device costs assumed for economic analysis.

In addition to the variable costs listed above for boilers and cooling towers, the quantities of this equipment needed are small enough to also consider a fixed cost; we based this on RS Means 2009 data.

ENERGY RATES AND OTHER INPUTS

Utility rates for the study (including all previous cost savings estimates) were taken from actual utility rates paid by the owners of each site. These utility rates are summarized in Table 7.

			Cashman	East CTA	Tobacco Lofts Residential	Tobacco Lofts House
Electricity	Customer Charge	\$/month	211	215	9	36
	Cons., off-peak	\$/kWh	0.057	0.057	0.139	0.079
	mid-peak	\$/kWh	0.078	0.074	0.139	0.079
	on-peak	\$/kWh	0.104	0.098	0.139	0.079
	winter	\$/kWh	0.064	0.060	0.128	0.068
	Demand, off-peak	\$/kW	0.000	0.000	---	---
	mid-peak	\$/kW	1.900	2.400	---	---
	on-peak	\$/kW	13.79	16.83	---	10.76
	winter	\$/kW	0.35	0.50	---	8.76
	Ratchet	\$/kW	3.10	3.36	---	2.50
Gas	Customer Charge	\$/month	150	125	10	19
	Consumption	\$/therm	0.80	0.80	0.97	0.83

Table 7. Utility rates used in all energy cost calculations in this study.

Maintenance costs were included in the study to show some demonstrated savings from using a GHX in place of boiler and cooling tower equipment. Research has shown a wide range of different potential savings (and in some cases, penalties) from this advantage. In a thorough search we found only four U.S. studies from the last ten years directly comparing maintenance costs in similar buildings with ground-source systems and conventional systems. The average demonstrated annual savings from those studies was \$0.10/ft²; this is the value we assumed in this study. A third of this benefit was taken away for calculating savings in hybrid systems, since there is some conventional equipment to maintain. We also needed to consider typical water costs for balancing the inclusion of cooling towers, relative to other options (a significant amount of water is evaporated in cooling tower operation). In this case, water costs

were assumed to be \$4 per 100 ft³ of water consumed, at the upper end of the rate structures for the Las Vegas Valley Water District.

One additional economic factor is replacement cost (and conversely, salvage benefit). The different pieces of equipment used in these HVAC systems have different expected lifetimes, so equipment replacement costs must be factored into the life-cycle cost. Additionally, since the period of economic study must be finite (in this case 20 years) there is often value remaining in equipment at the end of the study period—the salvage value of the equipment. To determine the impact of these factors, the costs above must be applied using typical lifetimes for each piece of equipment. Equipment lifetimes are based on ASHRAE published data (ASHRAE 2007). Rooftop equipment, chillers, and air handlers are given a lifetime of 15 years, residential furnaces are expected to last 18 years, and heat pumps are expected to last 19 years. The GHX is expected to last the life of the building (50 years is used here). All other equipment is assumed to last the 20-year study life.

RESULTS

Our study had a broad set of goals aimed at advancing the understanding of effective HyGSHP operation. The study resulted in the creation of data and models to aid the industry in analyzing hybrid options. But the study also included documenting some specific lessons learned from these systems and their designers. And finally, with the substantial benefit of hindsight, we can look at the design and operation of these systems and determine ways in which future projects may be implemented even more effectively.

OPTIMAL SYSTEM SIZING

Use both energy modeling and established best practices for sizing the plant components, taking extra care with building load calculations. All HVAC systems are sized using building loads that are based on broad assumptions regarding the construction, operation, and environmental conditions that a building will be exposed to. In a hybrid system the key components to be sized include the GHX, cooling or heating supplemental device (e.g. boiler, cooling tower), pumps, and heat pump equipment. The GHX has the highest incremental first cost (per capacity) of any of these components. Therefore, in these cases it is most cost effective to purchase a GHX that can be used to its maximum potential for both heating and cooling, keeping the utilization rate of this expensive component as high as possible. The remaining peaks can then be met by the supplemental device. For these reasons it is economically optimal (as suggested by Kavanaugh 1998, further shown by Hackel, 2009a) to size the GHX for the smaller of the heating/cooling loads, and to use the supplemental device for the remainder of the larger load¹¹. This can result in substantial economic savings over traditional GSHP-only systems and is the largest economic benefit of the hybrid approach.

For all HVAC systems the actual loads end up varying from those assumed when sizing equipment. As a general practice, the designer errs on the side of oversizing equipment since a failure to meet significant loads is generally considered worse than the additional cost of oversizing. But the additional cost of oversizing is substantially higher with any ground-source system for two reasons: first the first cost of ground-source systems is substantially greater than conventional equipment, and secondly, the pumps in these systems generally have a limited ability to turn-down, resulting in poor system operation if they are significantly oversized. The hybrid approach substantially mitigates the first issue in two ways: 1) it substantially decreases the size of the GHX, and 2) it allows the safety factor for the critical of the two loads (heating or cooling) to be applied to the supplemental equipment, allowing for a minimal safety factor on the GHX.

But designers must still take care in right-sizing the components in these systems to avoid unnecessarily large first cost. In the three systems we studied, the total plant capacity (including GHX and supplemental equipment) was indeed oversized. This is somewhat evident from observed operating temperatures; at Tobacco Lofts, for example, the *design* operating temperatures of the system were 32°F at the low end and 90°F at the upper end; the system is actually seeing temperatures range between 40°F and 85°F, with the supplemental boiler not being used in any substantial manner in the past year (see Figure 9 and Figure

¹¹ Though this statement summarizes the established basic strategy for sizing hybrid systems, those interested in learning about sizing should read the two references shown here in more detail. Also, refer to Kavanaugh, 1997 for a more detailed sizing algorithm for hybrids that is based on the popular methodology in the ASHRAE Applications Handbook.

10 for plots of these temperatures). At Cashman, the design temperatures were 50°F and 90°F; the system is operating in a range between 65°F and 90°F, with the cooling towers operating less than 15% of the time during the cooling season (a fraction of what was planned). The same story is occurring at East CTA, where temperatures are ranging between 60°F and 90°F and one of the towers has negligible run time. Considering temperature ranges alone does not allow us to identify oversizing, as controls often allow the temperatures to drift higher and lower than what the plant is capable of providing. To determine the degree to which the plant capacity is oversized, the actual building loads were used to optimize the sizes (and at the same time, control settings) of the components, based on finding the lowest life-cycle cost for the system¹². Table 8 demonstrates the optimal sizes of the equipment at each of the three sites as compared with the actual installed sizes.

	Ground Heat Exchanger		Supplemental Device	
	Actual	Optimized	Actual	Optimized
Cashman	144000 ft	86000 ft	500 tons	430 tons
East CTA	168000 ft	92000 ft	333 tons	400 tons
Tobacco Lofts	10900 ft	7400 ft	199 MBH	300 MBH

Table 8. Optimal sizes of equipment compared with actual installed sizes.

Note that in all three cases the GHX size is significantly larger than the optimal case, but in two of the three cases the supplemental device (boiler or tower) is smaller than the economic optimum. This shows that the overall capacity of the system is not as far off optimal as the GHX numbers suggest, but rather simply too much of the capacity is shifted to the GHX. This reflects the fact that the supplemental equipment in these cases was sized arbitrarily (e.g. at East CTA it was simply 20% cooling tower) due to a lack of design and optimization tools. This oversizing resulted in substantial increases in both the first cost and life-cycle cost of the equipment. The life cycle cost impacts will be discussed in depth in the ‘Life Cycle Cost Comparison’ section. The impact on first cost is fairly straightforward—a *large* increase in first cost is shown in Table 9 for not right-sizing these systems. Hybrid projects can avoid these costs by taking more care not to oversize the buildings loads (a very typical design problem, with atypically large consequences in ground-source), and using a detailed algorithm/tool for sizing individual components (see Kavanaugh 1998, tools like TRNSYS, or the *HYGCHP Tool* section below).

	GHX optimized savings (\$)	Suppl. device optimized savings (\$)	Total first cost savings for optimized equipment (\$)	Total first cost savings for optimized equipment (\$/ft ²)
Cashman	690200	17640	707840	3.5
East CTA	904400	-16884	887516	3.5
Tobacco Lofts	54600	-2192	52408	0.9

Table 9. Cost increases due to oversized equipment.

¹² The actual loads used in this optimization were obtained from a combination of measurement and calibrated models. Optimization throughout all areas of this project was accomplished through a combination of broad parametric studies and use of the GenOpt software (Wetter 2010), which allows for a computationally efficient optimization of computer models such as those in TRNSYS.

One primary reason that finding an optimal size for the GHX and cooling tower combination is so difficult is the fact that the capacity of this equipment changes for each hour of the year. For the cooling tower capacity is dependent on OA temperature and loop temperature, and for the GHX it is dependent on both loop temperature and the thermal storage history of the ground. As an example, at Cashman during the hottest portion of the cooling season, the cooling tower is providing a substantial portion of the heat rejection (the same order of magnitude as the GHX). Figure 13 demonstrates this during a few days in mid-summer. However, note that at the same site the annual heat rejected by the cooling towers is 842 MMbtu, while the annual heat rejected and absorbed by the GHX is 4984 MMbtu.

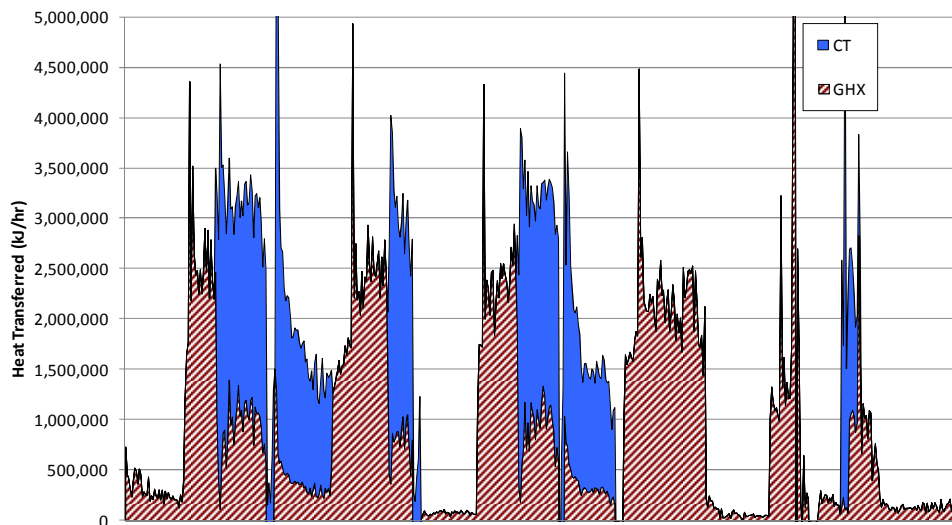

Figure 13. Sum of energy flow (the two series are stacked) during a few summer days at Site 1, both heat rejected by the GHX and by the cooling tower.

Consider use of 8760 load calculations for sizing whenever possible. For the reasons above there are significant benefits in sizing systems using hourly ('8760') loads calculations, rather than the simple peak heating and cooling load calculations used to size most conventional HVAC equipment. When coupled with a quality model of the GHX, these hourly (or even sub-hourly¹³) calculations allow for full accounting for the ground's thermal storage effects, local temperatures, and changing loop temperatures (not to mention transient components in the building, such as thermal mass). There are beginning to be more tools available for using hourly loads for sizing (including TRNSYS, EnergyPlus, HyGCHP, and eventually, eQUEST). These tools are much more complicated than standard peak load calculations, so it is still a good idea to conduct the peak load calculations and understand the differences in the two methods¹⁴, so that the most appropriate size can be carefully—and safely—chosen for the various equipment in the system.

¹³ Further refinement is gained from going to 15 or 30 minute timestep in analysis of the GHX and other plant components; we used this approach in our study with TRNSYS. Other programs also have this capability.

¹⁴ Hourly (8760) load calculations using energy modeling software often use TMY (typical meteorological year) weather. It is worth noting that the peak hour of the TMY data for these two sites is slightly more extreme (between 3-9°F) than the ASHRAE recommended design temperatures (based on Standard 90.1-2007).

PUMPING

Pumping design and control is important to HyGSHP (and GSHP) system performance. If just HVAC “plant” energy consumption is considered, pumping makes up: 7% (0.4 kWh/ft²) of the system energy at Cashman, 12% (0.4 kWh/ft²) at East CTA, and 21% (0.8 kWh/ft²) at Tobacco Lofts (see Figure 26 for more details). A few lessons were learned for keeping such numbers low on HyGSHP projects.

Focus on reducing installed pumping power throughout design. There is no single perfect pumping system for any large GSHP system—challenges include very large swings in pumping demand, decreasing GHX capacity at low flow, and long pipe runs. One robust piece of guidance is to focus on keeping the required pump power low throughout all steps in system design. One definition of low is Kavanaugh and Rafferty’s (1997) grading scale for pumping design in which 5 hp per 100 tons (of peak block load) is seen as a best achievable level, and 7.5 hp per 100 tons is considered a good target. The three sites we studied demonstrate the challenge of those targets: peak pumping power is 11.9 hp/100 tons of peak block load at Cashman, 16.9 hp/100 tons at East CTA, and 23.5 hp/100 tons at Tobacco Lofts.

The design teams in the three projects were successful in keeping power as low as they did by focusing on most of the following strategies:

- Design piping system to attain pressure drops below 25 feet through the GHX and below 60 feet for the system. Some of the following techniques focus on this sub-goal.
- Use larger borehole piping when flow rates and borefield size allow. The Cashman and East CTA sites used 1.25” piping . Larger sizes are available (Reynold’s number should be calculated at typical expected flow rates to ensure turbulence—minimum flow does not need to be turbulent).
- Increase pipe header sizes running to and from the borefield. Here turbulent flow is not a concern (all three projects we studied were sized to meet the recommended target of 1-3 ft of head per 100 ft of pipe (Kavanaugh 1997)). For smaller systems like Tobacco Lofts, the borefield can also be located close to the end of the heat pump loop, which reduces header length.
- Decrease valving and connections wherever possible in the borefield. Specifically, the designers of East CTA and Cashman no longer use balancing valves on projects; if the borefield is designed for balanced flow there will be no negative effects. Similarly, extraneous valving and fittings should be avoided at the heat pump unit itself.
- Consider avoiding or at least minimizing antifreeze. At Cashman and East CTA, ground temperatures are high enough that fluid temperatures would never approach freezing—therefore antifreeze is avoided and pump power is kept lower. Modeling studies (Hackel, 2009a) have shown that in many cases the total LCC of a hybrid system may be significantly lower if the GHX is designed to a much lower minimum temperature (often requiring antifreeze), allowing the GHX to be much smaller. The first cost savings surpasses the energy cost penalty—again, it depends whether the goal is to save energy or achieve an economic optimum. In any case, required antifreeze concentration should be calculated with care.
- A de-coupled primary/secondary configuration for the GHX/Supplemental loop was used for all three projects we studied. They found that pump power could be reduced by sizing one pump specifically for the building heat pump loop, and sizing different pumps for the GHX and supplemental devices. (Note in discussion below that this had some undesirable effects on part load efficiency, but with the right design could be an effective method).

Designers also reported that designing for pumping efficiency had other benefits as well. For example, the hydronic systems are generally simpler to install, balance, and purge, and as a result cost less up front.

Independently pump small, irregular zones. At Cashman, only one small zone (the 24-hour Security office) is occupied on many nights, weekends, and holidays. This one zone requires that one of the two large building pumps be left on. Associated energy waste is mitigated by the fact that the circuit serving the Security office only has a 7.5 hp pump, which is fortunately designed for excellent turndown (the other circuit is 40 hp). A similar situation occurred at East CTA, where the domestic hot water heat pumps required after-hours operation to maintain temperatures in storage tanks or for nighttime cleaning needs. Because these water-to-water heat pumps are sized reasonably large to meet peak conditions, they require a proportional fluid flow to be on after hours. The design and operation team is currently working out a solution to this problem. Energy savings are not tremendous for this improvement (on the order of \$500-\$1,000 in energy cost for each of these two situations) but the savings in maintenance and equipment is likely larger if a small independent pump is able to be run in place of the large building pump during these hours. If one or two of the smaller zones in a large building are driving the system to operate when all other zones are off, consider independently pumping those zones.

Part-load pumping power must be a focus of both design and operation of the system. Efficient part-load control of pumping can be even more challenging than peak load design, but it is (arguably) more important. At the sites studied, the limitations on part-load performance are due to a variety of reasons:

- Pump oversizing, leading to limited turndown due to pump curves and VFD limitations
- Limitations placed on VFD controls (both necessarily *and* unnecessarily)
- Concern over laminar flow in boreholes

As a result, as load decreases, the pumping power per ton increases fairly rapidly, as demonstrated in Figure 14.

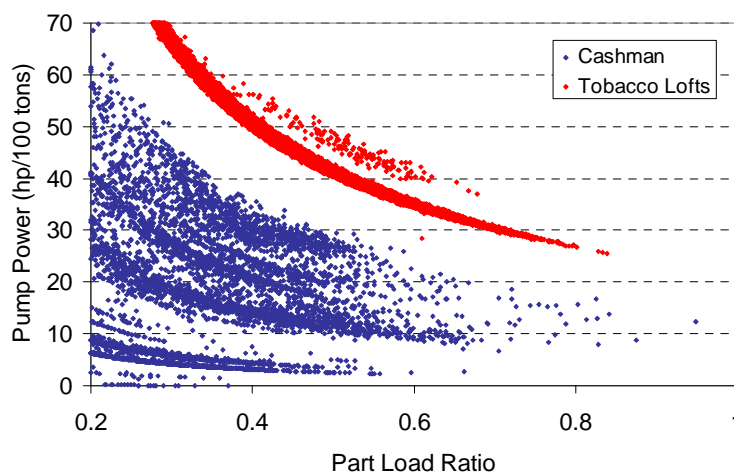

Figure 14. Part load energy efficiency of pumps at each facility.

We can draw two conclusions from Figure 14. First, as with the major plant equipment, the pumping equipment performance at full load is of limited importance—most data points occur below 80% part load. Secondly, the lack of any real variable speed pumping at Tobacco Lofts (there were VFDs but they

were not functional) results in significantly worse performance at part load; as would be expected—than the clouds of low power operation at Cashman.

Even at Cashman, multiple improvements could still be made to pumping design and operation. Firstly, the variable speed building pump on the main building only reaches about 42% speed at a minimum¹⁵ (at which point it is in or near “churn” at low loads), due to both controls and equipment selection (a well-designed VFD-driven pump should be able to reach 25% speed). This results in unnecessarily high flows of well more than 5 gpm/ton. The pressure differential (ΔP) controlling the pump speed may be able to be reset at low load to mitigate this problem (or just turned down all the time—the sensor itself may require a relocation to achieve this). Lower ΔP setting would allow the speed to decrease further. But in hindsight, it appears that another, more effective solution in this situation would be to use a smaller building pump, or a combination of two pumps such that a smaller pump can be energized at part load.

Furthermore, the GHX pumps are set to be on almost continuously, only shutting off for a narrow deadband of operating temperatures, and when no heat pumps are operating. Allowing for GHX pumps to shut off and the borefield bypassed when fluid temperatures are in a reasonable deadband (55 – 80°F) would yield significant savings as well. When temperature is moderate (see optimal setpoints discussion) the GHX pumps should be able to turn off. Using the model, we are able to determine how much additional energy could be saved by the hybrid system if all three of these improvements were made: 1) improving main building pump selection to peak efficiency of 72%, 2) using two pumps so that one is running at peak load at approximately 50% flow¹⁶, and 3) placing a better deadband control on the GHX pumps. These would result in a total of \$4,800 (40% of pumping energy) in additional savings per year. A similar level of savings could be achieved (approximately \$4,000/year) by pumping both the GHX and buildings using the same variable speed pumps, assuming that pumps could be found that matched the efficiency rating (mentioned above) even with the additional GHX pressure drop. Designers of Cashman were wary of this approach because flow would be laminar in the GHX at times; in hindsight the data shows that the loop would reach this flow rate for less than 4% of the load (and this flow would occur at such low load that reduced GHX capacity would be negligible to heat transfer).¹⁷

At East CTA the pumping design is very similar (even a little more oversized), so we saw the same part load inefficiencies discussed for the Cashman building pumps (regarding the inability to turn-down) there as well. This problem is exacerbated by the fact that the chosen pumps have a very flat curve at low load (not uncommon for such high volume pumps). This leads to difficulty controlling and balancing the system at low speeds; the differential pressure controller has significant trouble maintaining ΔP in this regime because 1) even large changes in pump speed result in almost no change in ΔP due to the flatness of the curve and/or 2) the ΔP gauge was not optimally placed. This issue is still being investigated by the operating team. In any event, turning down the building pumps to a reasonable minimum of 25% speed would result in approximately \$2,030 saved per year (a 39% savings in pumping energy). Adding a new,

¹⁵ The other building pump, serving the outlying buildings, is sized and controlled more appropriately, reaching a 30% minimum with little room for additional savings.

¹⁶ From examining pump curves it seems unlikely that any one secondary pump size, such as the 50% mentioned here, will be near optimal in every building. Each unique system and pump match should be analyzed to determine whether the smaller pump should be 40%, 50%, 66%, or some other fraction of the load.

¹⁷ Heat transfer rate in this laminar flow regime is an average of 7% lower than in the turbulent regime for the Cashman GHX, according to the GHX model. With less than 4% of the load being affected by this reduction, the energy impact is very small.

smaller pump to handle the majority of the hours when there are low loads would have a similar—and likely somewhat greater—effect.

At Tobacco Lofts the pumps are somewhat oversized as well, but that is not the primary reason for their inefficiency. More importantly they currently have no part load control. The GHX pump is constant-speed, and never shuts off (due to on/off noise complaints from tenants). The building pumps had VFD's, but they are not working correctly and do not allow any significant part load reduction (staff is in the process of fixing this issue; but anecdotally this issue is often encountered in smaller facilities). If the ground-source pump were able to be shut down within a deadband of 48 and 65°F (much of the summer) we would save \$920 per year. Additionally, if we effectively change the building pumps from constant back to variable speed, that savings increases to \$1,990. And for a building and loopfield this size, there is no reason that the GHX cannot also be served with the same variable flow pumps; switching the entire loop to variable speed pumping (with one ~60% pump) would increase the savings to \$2,730 (a 49% reduction from current pumping energy).

COOLING TOWER CONTROL

Configuration and control of the tower is also critical to the performance of the system. Controls must be used to continually determine when it is effective to use the supplemental device instead of or in addition to the GHX. To get a clearer picture of these impacts, the efficiency of the GHX can be considered relative to that of the supplemental device. Here, efficiency is measured as the heat rejection or absorption of the component per unit of energy consumed (COP) for pumps, fans, and boilers. The relative efficiency of these devices can be compared as shown in Figure 15. For Cashman, the GHX is generally, but not always, more efficient than the cooling tower. Interestingly, the performance of the GHX is substantially worse when the cooling tower is running, due to the fluid temperature being depressed by the tower (and low wet bulb in this climate). Additionally, as expected the tower is less efficient during periods of higher wet bulb temperatures. Our optimization of the control of the system depends on these tradeoffs.

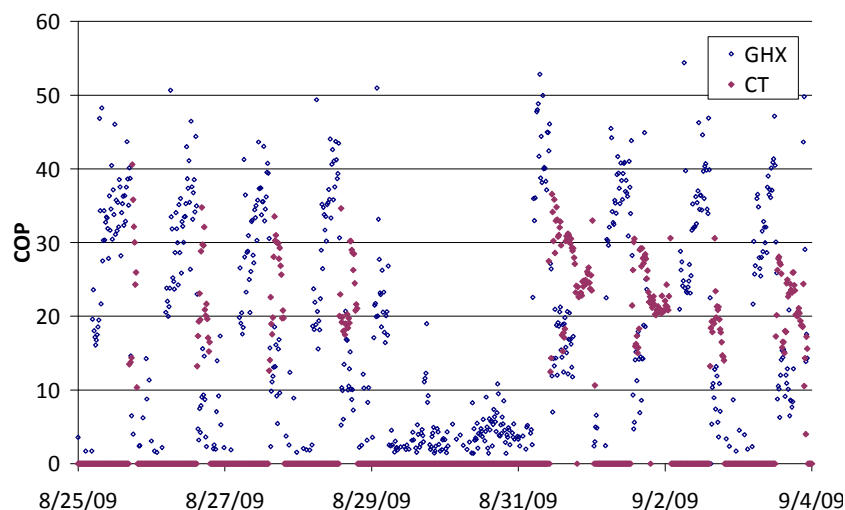

Figure 15. Efficiency of cooling tower operation vs. GHX operation at Cashman.

Choose variable speed cooling tower equipment, and ramp speed appropriately. The cooling mode sequence currently employed at both Cashman and East CTA, which is partially evident in Figure 15, first

brings on the GHX in stages to attempt to meet a cooling setpoint in the loop; when the entire GHX is being used and the setpoint is still not met, the tower is able to come on. The towers begin at low fan speed, and ramp up to full speed to maintain the setpoint if necessary. They then ramp down together; once they are off the GHX circuits are free to stage off as well.

Ramping the towers up together is more energy efficient at lower loads than ramping one tower up until it is at full load; this is because the power consumption of the fans drops off at the cube of their speed, while the performance of the tower does not decrease as quickly. This sequence is demonstrated effectively at Cashman because the loads generally cause a large enough spike for both the towers to come on during a summer day. If loads were slightly lower, or more uniform, such as in East CTA, there could become times when one tower is on without the other, which is suboptimal. In fact at East CTA, one tower runs for most of the summer months, switching between low and high speed (they only have two speeds) to meet cooling loads; a second tower only rarely comes on during the maximum loads. Some amount of additional energy could be saved by running both at low speed during much of this time.

Optimize the cooling tower setpoints; consider optimizing both during design and after some operational experience. The optimal cooling tower “on” setpoint for this sequence (using the same analysis process as discussed in *Optimal System Sizing*) at Cashman is 86°F (as opposed to the design setpoint of 90°F). The optimal setpoint at East CTA is 89°F (essentially the same as the design setpoint). Optimization also results in a fairly small deadband—once the towers are able to meet the load and temperatures drop back a small increment ($\sim 2^\circ\text{F}$) below setpoint, the towers’ speed should be ramped down, and eventually shut off, reasonably quickly. This differs from the design deadband on these projects of about 8°F. At Cashman, for example, this larger deadband results in close to an hour of operation at part load after the building load has ramped back down. Optimizing the on and off setpoints at Cashman results in a savings of \$2,600 per year (28% of cooling tower energy; a LCS of \$0.20/ft²). Due to the complexity of establishing these optimal setpoints and the large difference between predicted loads (at design) and actual loads as demonstrated earlier, it seems there is a lot of benefit in adjusting and/or optimizing setpoints after some actual operational/load data is available. This can be done by the firm conducting the measurement and verification of the building if applicable.

Check heat transfer direction in GHX during tower operation. In looking at the GHX load/efficiency plots, we noticed that during some of the run-time of the towers at the Cashman site, energy is being extracted from the ground and expelled by the towers (Figure 16). This is inefficient, since significant heat pump operation occurs at these times, and is made less efficient by the energy extracted from the ground. Even if the argument could be made that the GHX requires substantial recovery hours in this system (as in the precooling strategy), this is not the time to do so since ambient temperatures and electric rates are high during this scenario.

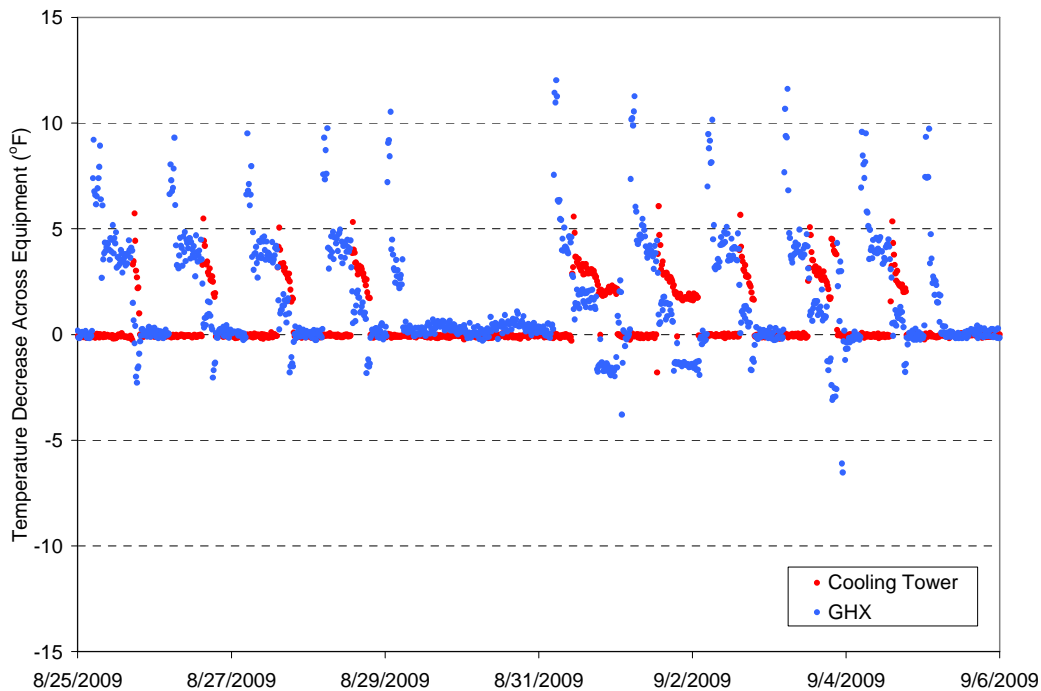

Figure 16. Temperature drop across tower and GHX during cooling mode demonstrating that while the tower is on, the GHX can sometimes be transferring heat in the wrong direction (extracting heat rather than rejecting it).

This occurred for 140 hours in the year studied; not a large enough time to result in significant energy lost. But at Cashman there are only 450 hours of cooling tower run time in the year, so this is occurring during a substantial portion of the towers' operation. In a system in which the towers were used significantly more (like a ideally sized system) the energy penalty could be substantial. This is an argument to either 1) monitor ΔT across the GHX and bypass the GHX if it has the same sign as the ΔT across the building, or 2) ramp down the GHX usage independently of the tower usage (this control is currently being added at East CTA, for example).

Consider additional research on cooling tower control. There has been one recent comprehensive study of control options for cooling dominated hybrid systems, conducted by Xu (2007), which we looked to for additional possible improvements to these systems. Xu considered other, more advanced methods for control of the supplemental device (beyond control based on simple setpoints). He suggested that optimization of setpoints did not result in substantial savings in many situations, and other non-optimized approaches may be more easily applied anyway. Some of Xu's methods used forecast control to determine—at any given time—whether running the cooling tower was likely to save energy based on the forecasted impacts. But these were deemed too complex to implement in any straightforward manner at these sites. Other methods based cooling tower operation on the current loads in a building, which is more straightforward than forecasting. One such iteration used the temperature change (ΔT) across the heat pumps as a proxy for load—assuming that even in a variable flow system, the ΔT increases proportionately with cooling load. Though more straightforward, this method did not turn out to be practical at either Cashman or East CTA because the variable speed pumping arrangement did not result in a simple relationship between ΔT and load. At Cashman, for example, loads of 3000 MBH, 1500

MBH, 300 MBH, and 0 MBH all resulted in a ΔT of 4°F at various times. One other strategy suggested by Xu seemed applicable to the cooling towers at these sites. He proposed running the tower more often as the system temperature increased. The controls would calculate a rolling average of $T_{HP,in}$ over a week or so, as this value increased, the setpoint for the tower would be lowered to run it more often. A general equation was given for following this method. This option is feasible since these sites did exhibit increase in operating temperature as loads got worse.

The UW Solar Energy Lab will also be continuing to study cooling tower control in subsequent research projects.

COOLING TOWER CONTROL, FOR PRECOOLING

One of the main reasons hybrids are used is to mitigate ground temperature increase in hot climates. Depending on building loads, this could include running the cooling tower while there are no cooling loads in the building to “precool” the ground. In investigating this option, we first will discuss long term temperature change in general. A discussion of precooling control follows.

Long-term Operation and Temperature Effects

The addition of the supplemental device results in more balanced load on the ground around the GHX—meaning that the amount of energy extracted is closer to the amount of energy rejected—than would be the case with a GSHP-only system. This affects life cycle cost in a couple ways.

Firstly, the GHX does not need to be increased in size to account for *full* degradation of borehole performance over time; the resulting cost increase from a larger GHX is then avoided. For example, in a cooling-dominated system this degradation occurs because the ground accumulates more and more heat—on a net basis—each year, resulting in steady increase of the average ground temperature across the field. In year ten (many GHXs are sized based on 10-year operation) the ground is significantly warmer than its undisturbed temperature, and each borehole provides less cooling capacity as a result.

The other potential primary effect of more balanced ground load is more constant temperature of the fluid exiting the GHX. In this way hybridization can cause $T_{HP,in}$ to become less extreme, as shown in Figure 17 in which $T_{HP,in}$ is plotted for the first 10 years of operation; this generally would result in less heat pump energy consumption. But other modeled cases have demonstrated cases in which the optimal sizes and control setpoints of these systems deliver a $T_{HP,in}$ at or near the limit of the system (which would be 30°F in the case of Figure 17). In this case the GSHP system, not the hybrid, would yield more moderate $T_{HP,in}$ and use less energy for most of the operating years because an unbalanced GSHP system only reaches the temperature limits in the final year of analysis.

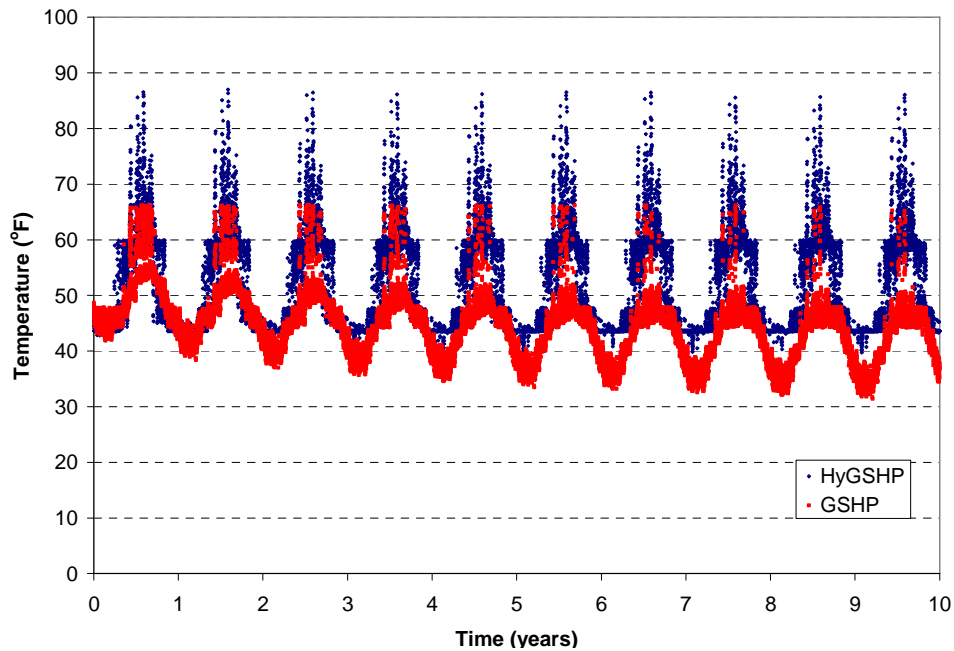

Figure 17. Long term value of $T_{HP,in}$ for Tobacco Lofts for both hybrid and GSHP cases.

Though optimal design of a HyGSHP naturally results in a *more* balanced ground load, it does not necessarily have to result in *complete* balance. In any system optimization with a finite lifetime a certain amount of ground temperature change often results, even for hybrids. For example in our study we assume a 20-year timespan for LCC calculation/optimization (similar results would be expected for 30 years). Economic optimization of this finite lifetime often still results in a moderate temperature increase over the life of the GHX, such that eventually the system would violate temperature limits. It is assumed that at that time, adjustments would be needed to keep within the temperature limits—such as further increasing supplemental device run-time (a less likely later step may involve purchasing a larger supplemental device when it is time for replacement).

This runs somewhat counter to the strategy of assuming that optimal HyGSHP design/operation results in fully balanced ground loads, but it remains consistent with the finite timespans generally assumed for system design. Anecdotally, most designs we have worked with (by a broad array of designers) are also designed based on that finite lifetime of only 10 or 20 years, even though the systems are planned to last 50-plus years. For design purposes this has been appropriate for a couple reasons. First, the temperature increases by year 20 are generally small anyway, as most of the long term ΔT occurs in the first few years. And once timespans become as long as a couple decades, there is considerable disagreement between technical theories as to the magnitude of the temperature change (Phillippe, 2010), as no models have been calibrated over such a timespan. This is an area where future research is currently being planned by major national stakeholders such as ASHRAE; when such results are more accurately understood, all ground-source designs (and optimizations) may need some revision.

Precooling

Consider including a precooling sequence in your system; conduct analysis to ensure energy savings for your specific building. Precooling—in this case operating the cooling tower during summer nights (used at both East CTA and Cashman)—is one method used to push the system towards even more balanced ground loads. Even if complete balancing of the ground load is not necessary, it is possible that

precooling could save energy or operating cost due to lower nighttime electric rates and more favorable ambient temperatures (for tower operation). Precooling, as implemented in these buildings, does this by dropping the temperature of the GHX in the evening, improving ground heat transfer during cooling operation the following day.

There are a multitude of strategies which could be applied to precooling (Pardo et al. 2010; Jिंगgang et al. 2009). Due to modeling challenges, this study maintained focus simply on understanding impacts of a subset of precooling strategies on life cycle cost, long-term ground temperature, and energy consumption (a more exhaustive optimization of these strategies will definitely be an area of future research). Our precooling model consisted of operating the cooling tower at night during days with significant cooling loads (i.e. the cooling season), and when the GHX outlet temperature reached a certain setpoint the last time flow occurred.¹⁸ Cashman was used as the test case. There are four separate GHX circuits in this system, so precooling only occurs in the circuits where the setpoint temperature is violated. A broad parametric study first revealed that precooling tended to have lower life cycle costs when the tower was operated in its more efficient part load state, and if precooling was only done for a fraction of the night time. Initial setpoints were therefore set to 30% tower fan speed and two hours per night of precooling. Table 10 examines the effect of two parameters on precooling: the time of night that precooling begins and a threshold based on previous day's building load that determines if precooling is used. A base case with no precooling is shown in Table 10 for comparison. The threshold is used because we assume it's only sensible to operate precooling with a likelihood of significant cooling again the following day. The system is considered solidly in cooling season if the previous day's peak cooling load (as a percentage of maximum) is greater than the threshold (shown as either *10% Load* or *50% Load*). In lieu of this threshold, a knowledgeable facility manager could potentially just specify whether they know the building to be in cooling season. The effects of the threshold and time-of-night are demonstrated by: 1) system energy savings, 2) change in ground temperature over 10 years, and 3) resulting life cycle savings (LCS).

Precool start time	Energy Savings (kWh)		$\Delta T_{\text{ground}} (\Delta^{\circ}\text{F})$		LCS (\$)	
	<i>10% Load</i>	<i>50% Load</i>	<i>10% Load</i>	<i>50% Load</i>	<i>10% Load</i>	<i>50% Load</i>
-	0	0	2.21	2.21	0	0
1	37,251	-9,950	2.13	2.21	1380	471
4	42,793	-17,349	2.06	2.18	1225	725

Table 10. Energy savings, ground temperature change, and LCS with different thresholds and start times.

For all settings, the ground temperature increase over 10 years with precooling decreases, but the change is not significant. There is a modest energy savings and LCS shown, especially for the cases where the threshold of *10% Load* is used (as compared to a total LCC of about \$140,000 for operating the GHX pumps and the cooling towers that make up the plant equipment). We looked even closer at the effect of precooling start time, as shown in Figure 18. Note the clear trend in increased energy savings as the start time for precooling becomes later in the morning. The GHX is not a perfect thermal storage mechanism for cooling—energy from the surrounding ground flows back toward the borehole over time, negating the

¹⁸ This is very similar to the precooling strategy used at East CTA and Cashman, except that they were able to continuously monitor the GHX temperature throughout the night to adjust precooling. Our models were not capable of this, but the end result is similar fundamentally, and could be dialed to provide similar performance and precooling durations.

effect of the precooling. Based on the results shown in these two figures, as the amount of precooling increases, and as the start time becomes later in the morning, there is a large reduction in energy usage and a slight reduction in ground temperature change and LCS.

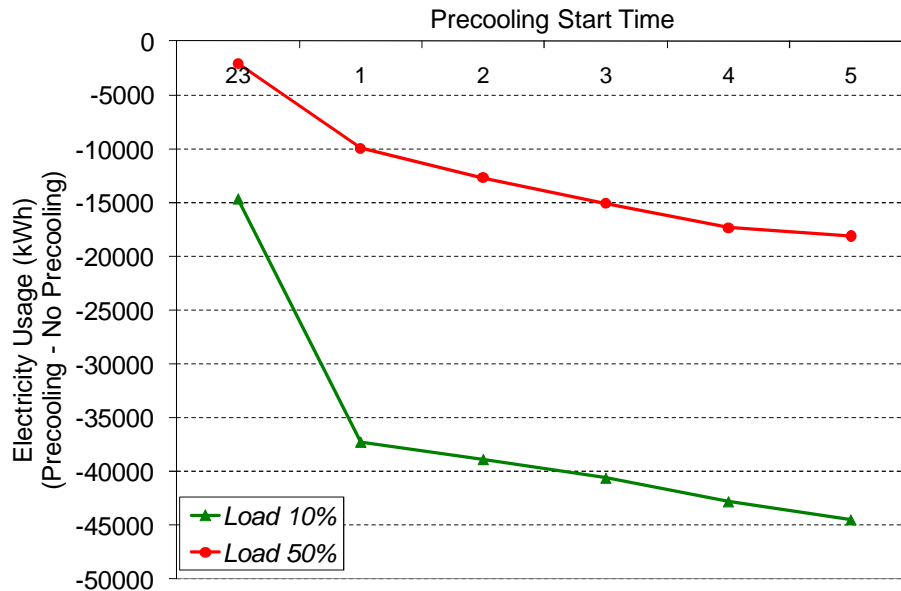

Figure 18. Difference between the electricity usage for a case with precooling and a case without precooling when the threshold is based on either the load or the time. Note that the usage decreases when precooling occurs in the morning hours.

While the percentage threshold above is a method for determining whether the system is solidly in the cooling season, a second setting is also used to determine if a GHX circuit has become warm enough to need precooling. We created a temperature setpoint, T_{PC} , to investigate this control. If the outlet temperature of the GHX during last operation is greater than T_{PC} , precooling is made available (a 25% Load threshold is used). Table 11 shows the amount of precooling, the energy savings, the ground temperature change, and the LCS as this setpoint is varied. When T_{PC} is large, there is relatively little precooling each year, but as the temperature decreases, the number of precooling hours increases. The general trend indicates that T_{PC} should be made relatively low (at least in the Las Vegas area).

T_{PC} (°F)	Precooling hours per year	Energy Savings (kWh)	ΔT_{ground} ($\Delta^\circ F$)	LCS (\$)
90	4.6	1,111	4.18	47
88	25	4,427	4.16	487
86	114	17,406	4.10	835
84	200	29,773	4.03	1756

Table 11. Number of precooling hours, energy savings, ground temperature change, and LCS with precooling as a function of precooling temperature set point (savings based on a base case of no precooling).

Finally, an additional optimization was performed, this time with precooling included and boundaries set on control optimization based on the learnings discussed above. Using these settings led to the results in Table 12. There is a significant savings associated with precooling (nearly 15%) as compared to a case without precooling, but there is still only a modest decrease in the ground temperature rise.

	Energy Savings (kWh)	ΔT_{ground} ($\Delta^{\circ}\text{F}$)	LCS (\$)
Base	0	3.76	0
Precooling	364,000	3.64	21,043

Table 12. Energy savings ground temperature change, and LCS with precooling included in optimization.

This study of precooling was by no means exhaustive, but some general statements can be made. First, it is apparent that precooling has the potential to reduce LCC; though it may not be large enough to warrant the complexity inherent in implementing such control in many buildings. In any case, caution should be used in the design of the strategy and the performance of the system should be monitored closely to ensure that it is behaving as desired—just running a cooling tower at night during the summer will not save energy; in fact in our sensitivities we identified several precooling strategies that increased cost.

Finally, examining the trends above indicates that 1) precooling is generally more effective if performed during the morning hours (but prior to both warm-up and peak electric rates), rather than earlier in the night, 2) allowing more precooling by using a lower load threshold setting leads to additional energy savings, 3) precooling can lead to a reduction in ground temperature rise, but the magnitude is small for moderate amounts of precooling—in fact it seems that a massive number of precooling hours would be needed to fully balance the load on the ground in the case of Cashman. Additional study will need to be conducted to investigate precooling, including other control strategies and even seasonal precooling.

GHX AND GENERAL CONTROL

Though not as critical as cooling tower or boiler control (because those use so much more energy when on), it is also worth considering optimal setpoints for control of the GHX, which as a default should have a bypass to save on pumping energy when loads are well balanced, or simply low. In the decoupled approach used at both Cashman and East CTA, the optimal setpoint for using the GHX (at the high end; for cooling) is about 9-10 $^{\circ}\text{F}$ below the optimal cooling tower setpoint. This results in a GHX setpoint of 77 $^{\circ}\text{F}$ at Cashman, and 80 $^{\circ}\text{F}$ at East CTA (as opposed to the designed setpoint of 85 $^{\circ}\text{F}$ at Cashman and 86 $^{\circ}\text{F}$ at East CTA).¹⁹

When the buildings are in heating mode (i.e. have a larger heating load than cooling load), the temperatures generally drop very quickly. Optimization showed that it was generally effective for the GHX setpoint in heating to be fairly high, so that the GHX is utilized quickly and $T_{\text{HP,in}}$ is kept as high as the capacity allows (note that this does not suggest that it is economically optimal to *size* the field for higher values of $T_{\text{HP,in}}$ in heating mode, but rather just to utilize the GHX starting at a higher temperature).

All three of these facilities use decoupled primary/secondary loops. This allows pumps to be designed to fit each loop more specifically (though this still needs to be done with care, to ensure proper part load efficiencies). But if primary/secondary control is used, consider referencing the $T_{\text{HP,in}}$ point in the

¹⁹ Cooling setpoint was not investigated at Tobacco Lofts; it didn't seem to have any strong effect on the results.

secondary loop for setpoint control (at $T_{HP,in}$), rather than a point in the primary loop. Primary loop temperatures are not always indicative of temperatures at the heat pump due to the bypass that is required in the primary/secondary arrangement. Control based on primary temperatures at Cashman leads to some extreme temperatures during times of zero flow on the primary side (see Figure 19). At the very least a trend like Figure 19 should be monitored by facility staff so that the differences are understood.

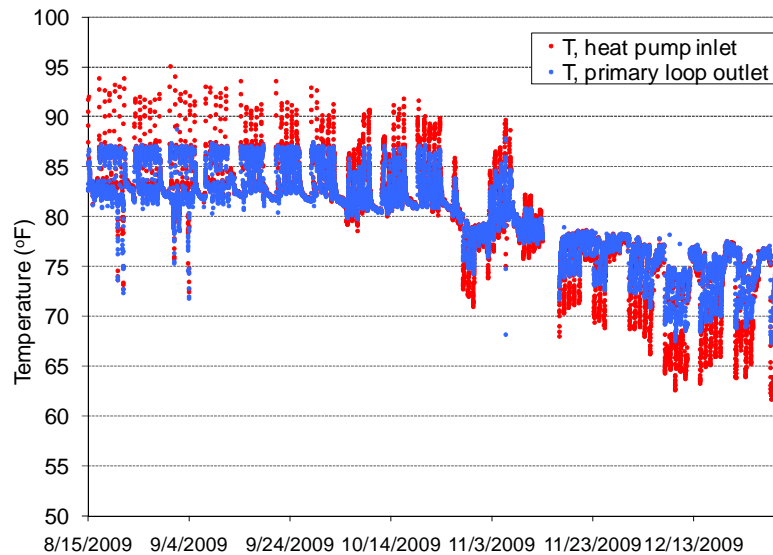

Figure 19. Temperatures in the primary (plant) loop and the secondary (building) loop (at the inlet to the heat pump). Note that the temperature at the heat pump inlet is not controlled nearly as tightly as the temperature in the primary loop, leading to potentially more extreme temperatures than designed for.

Due to the complexity of setting optimal setpoints and the large difference between predicted loads (at design) and actual loads as demonstrated earlier, it seems there is benefit in adjusting and/or optimizing setpoints after some actual operational/load data is available. This can be done by the firm conducting the measurement and verification of the building if applicable.

AN ALTERNATIVE TO HEATING DOMINATED HYBRIDS

Buildings that are heating dominated enough to significantly benefit from hybridization are not common in much of the United States. They only exist in severely cold climates or in buildings with large uncooled spaces. This is due to the load-dominated nature of most commercial buildings, the constant heat of compressors, and the increased usage of ventilation heat recovery to temper winter air. That's why we used a multifamily building in Wisconsin for the heating-dominated portion of this project. In the case of any severely heating-dominated building (approximately twice as much annual heating as cooling, or a substantial difference in four-hour peak loads) a supplemental heating device (e.g. boiler) could be considered to balance loads and decrease life-cycle cost. In an optimal system the ground heat exchanger is sized to meet the cooling load and a supplemental device meets the remaining heating load.

To simplify the HVAC system in such buildings, it is beneficial to first at least consider *directly* heating air or heating fluid in the building (since boilers, electricity, and solar all provide high enough temperatures for this) and avoid unnecessarily operating the heat pump. Delivering this supplemental heat via coils separate from the GSHP fluid system can increase system efficiency and eliminate the

problems posed in the indirect approach discussed in the next paragraph. This direct heating can be cost effective if it can be broken off as a separate system: dedicated ventilation preheat, baseboard perimeter heating, domestic hot water, or unit heaters are good examples that may be better served directly.

In other situations it may only be cost-effective to provide indirect heat through a supplemental heat coil on the ground-source fluid loop, as is done with a boiler at Tobacco Lofts. This option has some drawbacks. First, if controls are not maintained correctly, the boiler may dump heat to the ground; only a fraction of that rejected heat would be recovered. Secondly, in this approach, heat pumps operate whenever heating is needed, even though a high temperature coil is also operating. This, coupled with the need for a heat exchanger in some of these systems, adds significant and unnecessary energy consumption to the system. Finally, the high potential temperatures from the supplemental device may be not within limits of typical ground loop specifications and warranties, should the boiler not be controlled properly.

At Tobacco Lofts, much of the initial hybridization is already done using direct heat. There are baseboards in some of the units, there is baseboard in entryways, and there is direct heat for ventilation air²⁰. This amounts to about 65,600 kWh of direct heating usage each year, as opposed to the 268,000 kWh of energy used by the HyGSHP system. Of course, much of this is electric heat, so it is not the most effective method of taking this off of the ground-source loop—switching to gas heat on the ventilation air, for example, would have been a cost effective solution (switching from electric to gas heat in the dedicated outdoor air unit would have saved \$1,200 annually, for a LCS of \$0.32/ft²).

Even with this direct heat, the GHX design was still heating constrained, resulting in hybridization. But as discussed above, it may sometimes be simpler (or safer) to try to remove additional load from the GSHP system and supply it via direct heating gas fired sources. It is not likely to be practical to shift any heating coils in Tobacco Lofts to direct heat (as they are generally all heat pumps serving single residential zones). But in a lot of commercial buildings—especially those that are heating constrained—there are often systems that can be shifted off of the GSHP system: unit heaters in mechanical and garage areas, baseboard heat, vestibule heaters, or even outside air systems. We tested this approach by acting as if Tobacco Lofts had the capability to make such a shift, and experimented with shifting a certain amount of the heating load. If we could have shifted 45% of the heating load in this size building to a direct heating coil, a 20-year LCS of \$14,000 (\$0.26/ft²) would be realized beyond the savings already shown from the hybrid system. And the installation and operation of the system would be simpler for building personnel.

BOILER CONTROL IN A HYBRID

Design an appropriate boiler setpoint relative to the GHX operation, and inform facility management to only modify with caution. Of course there are some cases where the only feasible solution for a heating dominated system is to place a boiler on the GSHP loop. In this situation, the operation of a boiler/GHX combination must be done with care. Improper boiler and GHX setpoints can result in heat being rejected to the ground during heating season. In fact at Tobacco Lofts, after initially running the boiler too much and occasionally rejecting heat to the GHX, the staff rarely operated the boiler in the recent past due to warmer loop temperatures. Models indicate that over time the boiler will

²⁰ In keeping with the general theme of oversizing at Tobacco Lofts, the baseboards in the apartments, included as a supplement for the worst-case loads, are almost never used. The four baseboards monitored as part of this project weren't used during our study year. Other tenants also indicated that their baseboard heating wasn't used.

likely be needed again in a significant way when loop temperatures eventually fall. Without the boiler, and with average weather, the loop would likely degrade by about 0.5°F each year in the next five years. With a moderate boiler setpoint, the degradation is only about 0.1°F year *total* after five more years.

In a system like Tobacco Lofts', boiler performance is approximately constant (due to constantly condensing temperatures and operation) while the GHX performance varies. The GHX is generally more efficient at heat absorption than the boiler at Tobacco Lofts (see Figure 20), except as the system enters part loads in early spring (mid-March in this case, with similar behavior in fall). At this point, the constant speed pump is not able to ramp down proportionately to the load, and the boiler becomes more efficient. However, in this facility the $T_{HP,in}$ during these low-load shoulder seasons is in the range of 45°F-60°F, and the optimal setpoints for both the boiler and GHX are below this temperature; so it is optimal to operate neither during those times (this may not be true for all heat pump systems).

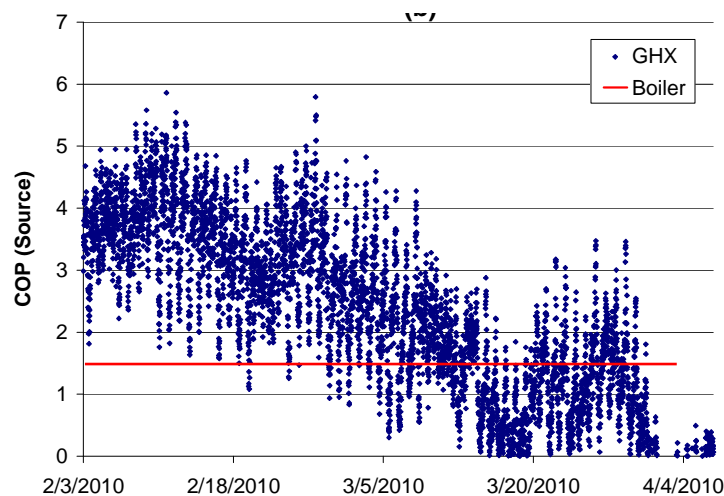

Figure 20. Efficiency of boiler operation vs. GHX operation at Tobacco Lofts. The source COP shown is roughly proportionate to cost as well.

In this case, the optimal GHX on setpoint is 45°F and the optimal boiler on setpoint is 40°F. Basically the boiler provides only a first-cost reduction benefit, and once installed should be operated as minimally as possible. And then, place the boiler downstream of the GHX and use a boiler setpoint that is lower than the GHX setpoint to prevent the boiler from dumping heat to the GHX.

HEAT PUMP OPERATION

We observed some energy impacts at all these sites that didn't directly impact design or operation of the HyGSHP system per se, but are useful tips for most heat pump systems.

Use some form of optimal start-up with heat pumps. Initially at East CTA, the outside air to some of the main spaces was set to activate when the occupancy sensors were activated in those spaces. However, this caused spikes in electrical demand, sharp drops in fluid temperature during start-up, and potential for increased wear on equipment. A quick adjustment was made to schedule outdoor air to maintain most of the air conditioning savings, while staggering it with the beginning of the internal loads.

Still, during winter morning warm-up—and to a lesser extent during summer cool-down—the power consumption of the heat pumps at both Cashman and East CTA spikes as ventilation goes from zero to maximum values during the time that the temperatures are returning to occupied levels. Meanwhile the heat pump is operating with minimum temperatures in the ground loop at these times, decreasing efficiency. A spike in power of between 10 and 45 minutes in length is generally the result. And as Figure 21 shows, this spike drives the peak demand for the winter months up by as much as 150 kW. Figure 21 only shows one week, but it is typical of other weeks. (This phenomenon is not seen at Tobacco Lofts; there is no ventilation on the HyGSHPs, and no central DDC system to allow control of all the systems so tenants are simply instructed not to set back their thermostats).

Staged warm-up is a well established solution to this problem, and is actually currently being worked on by facility and energy management personnel for these buildings. Staged warm-up involves not only warming up different areas at different times, but can also have ventilation air ramp up at a different time from the thermostat change.²¹ A more sophisticated approach would be an optimal startup sequence in the DDC system, in which the controller would vary the startup times of a few groups of systems until it approaching minimum peak power (while still meeting thermostat setpoint during occupied mode). In modeling this approach, we found that the savings at Cashman is actually minimal: approximately \$400 per year for a LCS of \$4,000 (\$0.02/ft²), which is as low as it is because Cashman does not pay any significant winter demand charge. However, for most buildings and regions there is a significant winter demand charge. If the Cashman winter demand charge were proportional to the summer demand charge—just 20% lower for example—the savings would be approximately \$10,300 annually, just for implementing on optimal start control. That's a LCS of \$99,000 (\$0.48/ft²) for the system.

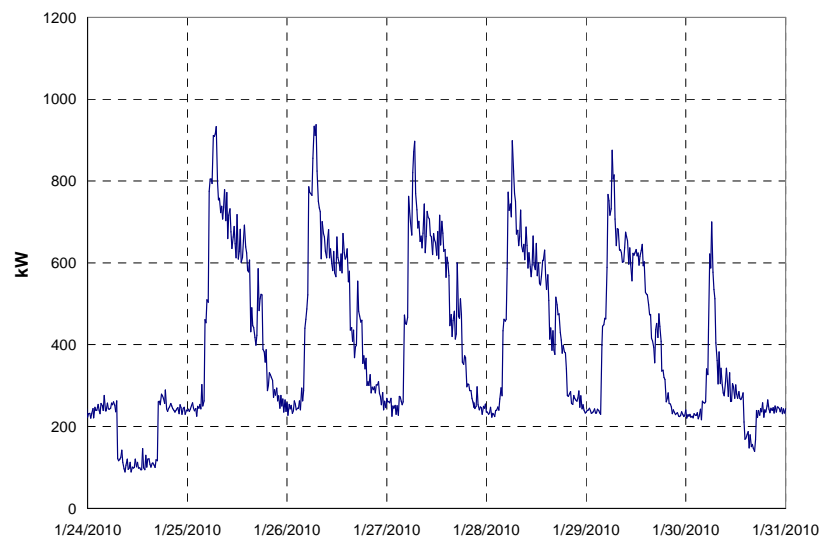

Figure 21. Power consumption at Cashman over the course of one winter week.

Consider sensitivities to varying heat pump performance during design. We monitored six (10%) of the heat pumps at the Tobacco Lofts, primarily as a calibration point for heat pump power consumption in

²¹ At Cashman the option of using CO₂ sensors to delay the ramp up of ventilation air is also being considered, so that ventilation ramp up could actually occur significantly later than the start of occupancy and thermostat change. Anecdotal evidence suggests that such a delay would result in multiple hours of ventilation energy savings.

the models. But we also measured enough temperature and flow data to determine the average operating efficiency of each of the units²²; a luxury that we didn't have at the other two sites. This allows us to do at least some minimal comparison between the heat pumps' actual operation and rated efficiency (according to the Air-conditioning, Heating and Refrigeration Institute, or AHRI, Standard 13256-1)²³. All of these heat pump units were single stage Trane Axiom GEH units, of various sizes. Figure 22 (for heating) and Figure 23 (for cooling) demonstrate, the observed heat pump operating efficiency varies significantly from unit to unit; in general it is near or somewhat lower than rated efficiency.

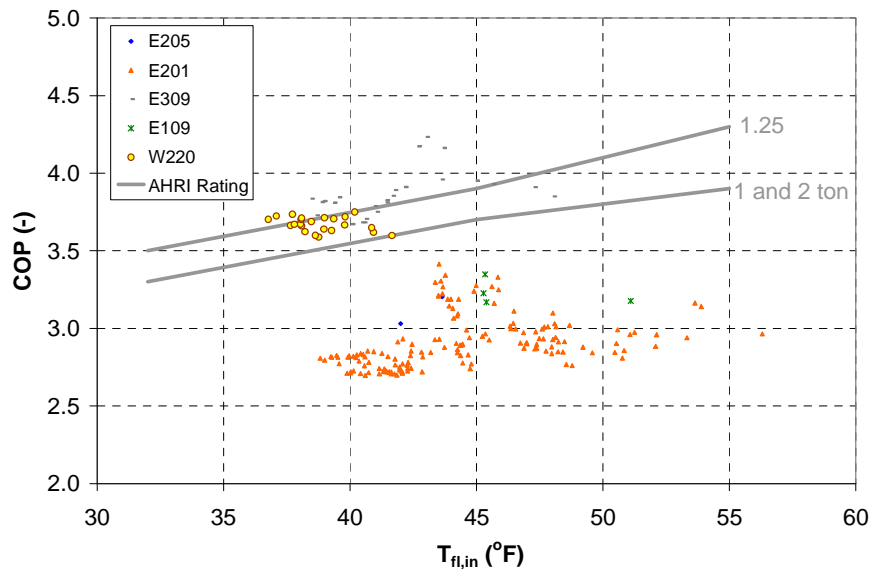

Figure 22. Heat pump operating efficiency in heating as a function of entering fluid temperature, as compared to the AHRI rating (and manufacturer documented temperature relief).

²² Accurate COP measurements were only retrieved from five of the six units; results from the current switch (measuring when the heat pump is on or off) for one of the units appeared to give erratic results, which are not shown or considered in average COP calculations.

²³ Efficiency can of course not be measured directly, but was calculated based on measurement of flow and temperatures. See the section on *Data Collection* above.

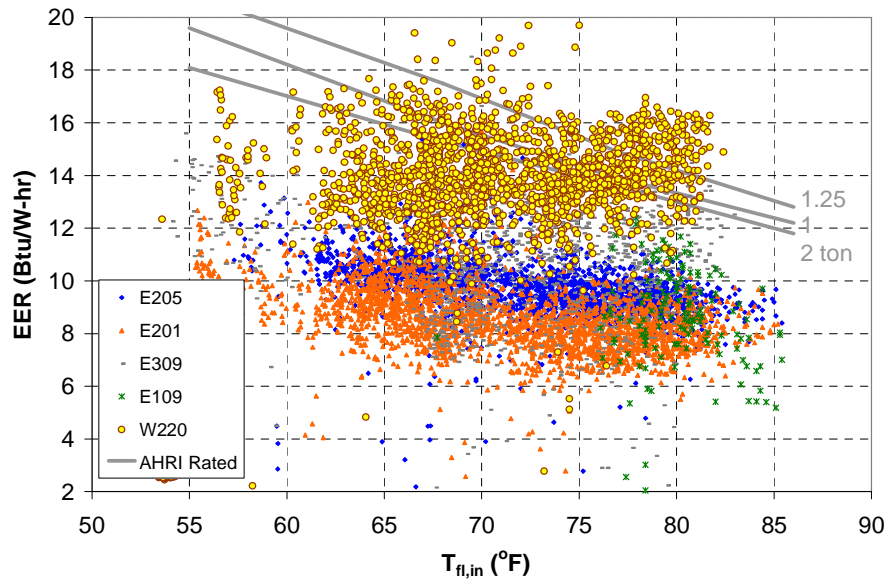

Figure 23. Heat pump operating efficiency in cooling as a function of entering fluid temperature, as compared to the AHRI rating (and manufacturer documented temperature relief).

These heat pumps have already been in service for six years, so age and maintenance could be a factor. Also, we did find that for these particular heat pumps, the efficiency was a stronger function of part load ratio than of temperature (which is not generally true of heat pumps). Figure 24 shows the heating operating efficiency of each of the heat pumps as a function of part load ratio; note that efficiency decreases significantly with part load (cooling exhibited similar behavior, though less severely).

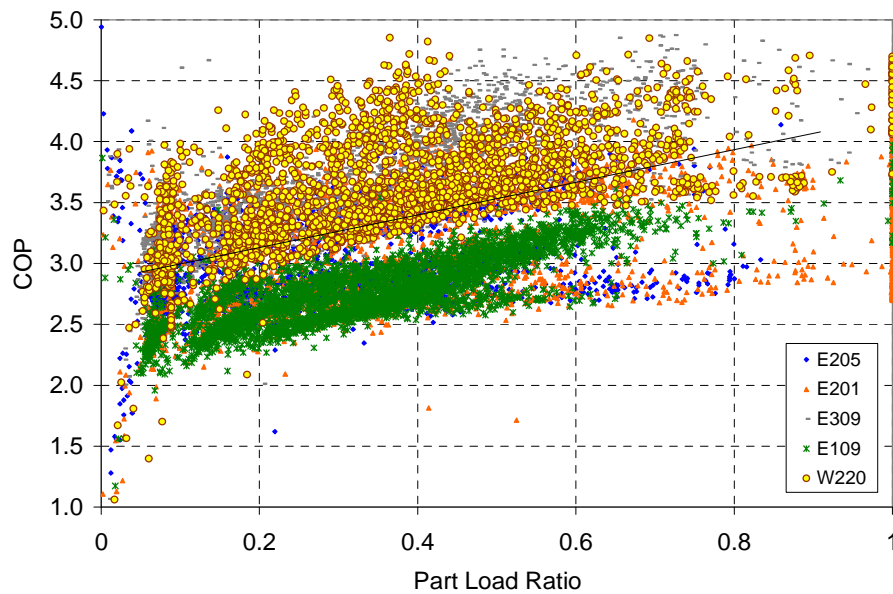

Figure 24. COP of the heat pumps monitored at Tobacco Lofts, as a function of part load ratio.

This part-load effect resulted in lower average efficiency than the rated heat pump efficiencies would predict (and even lower than many established heat pump models). Modeled results show that if all the heat pumps performed at the efficiency represented by the manufacturer (even with part load degradation)

there would be a \$5,800 decrease (10% of heat pump cost) in electricity cost per year. Incidentally, this is also one of the reasons that the GHX is oversized in this case. Though it may be difficult to rely on this during the GHX design stage, different sensitivities of sizing may consider at least the reduction in part load efficiency. For example, significantly less heat is extracted from this GHX at Tobacco Lofts than would be extracted with more efficient heat pumps (due to the extra compressor waste heat). One possible cause of poor part load efficiency here is in the sequencing of the unit. Fans come on a full two minutes prior to compressors. Then, valves open but only shortly before the compressor turns on; the slow valves do not deliver full flow to the heat pump until 1-2 minutes into compressor operation, making early compressor operation much less efficient. Other heat pump installations, including Cashman and East CTA, have a more favorable timing. But this issue may not be entirely isolated to Tobacco Lofts. Heat pump power consumption has been measured at higher than rated values in other research, in residential applications (Puttagunta, 2010 and Andrushuk, 2008).

Ensure a proper return air path. Designers, contractors, and commissioning agents also need to ensure a proper return air path for the units. Return ducting was part of the general design in most of the Tobacco Lofts units, but a couple of the apartments monitored had inadequate return ducting, which starves the heat pump of air and increases the return air temperature in cases where the unit is in a closet or small plenum. One space without any direct return air path had a return air temperature in heating that was 11°F warmer than other spaces, which would result in an 8% reduction in COP based on manufacturer ratings just due to the increased return air temperature. The additional effect of decreased airflow on the system was not measured. Most of the units studied (and all units at the other buildings) had a return air duct.

Use ECM motors. Electrically commutated motors (ECM) were used at Cashman; these motors save approximately a third of heat pump fan energy. But realize that if ventilation air is supplied at the heat pump, air flow should meet minimum required ventilation rates at the lowest ECM speed.

Consider unit accessibility. Heat pump filters and control boards both need to be accessible in all the units. This was a challenge that all trades had to be continuously aware of on these projects; for the most part their vigilance and that of the commissioning agent led to successful installation (though not always).

Choose a reasonably large deadband for temperature control. At East CTA, some heat pumps have been observed cycling between heating and cooling mode during short periods of time. This is most likely due to the deadband being too small on the thermostat control, causing it to overreact to small fluctuations in load. Though this is not as problematic as two separate systems simultaneously heating/cooling, it does lead to some significant additional energy cost.

Use partial economizer mode in the DOAS. The only additional system improvement that we recognized was the potential for the use of partial economizer mode in the DOAS. When the majority of heat pumps are in cooling mode, lower the temperature at which outside air is delivered to provide at least some free cooling.

ENERGY AND ECONOMIC ANALYSIS OF HYBRID APPROACH

The primary benefit of hybrid systems is their ability to lower initial cost. But the substantial change in equipment sizes and operation that accompanies hybridization also results in changes in annual operating costs due to changes in energy, water, and maintenance. And there are additional factors affecting

economics such as different equipment lifetime and tax effects. A full life-cycle cost assessment of these systems is therefore the most comprehensive method of comparing hybrid systems to GSHP-only systems, as well as more conventional system types.

Relative Energy Consumption of Components

Before computing the ultimate life-cycle comparison between various systems, we look at the energy consumption of the various components of the hybrid systems. This will allow us to understand more clearly the impact that the hybrid components have on energy usage, which is the primary driver behind the annual cost comparison between systems. The energy consumption data that was collected is supplemented with calibrated simulation data, and plotted by end use in Figure 25²⁴. Note that differences between the buildings are driven largely by the differences in building type, and not because one building is a significantly better performer than another. These values demonstrate the relative impact of each component of the HVAC system, as well as how these compare to non-HVAC systems like lighting.

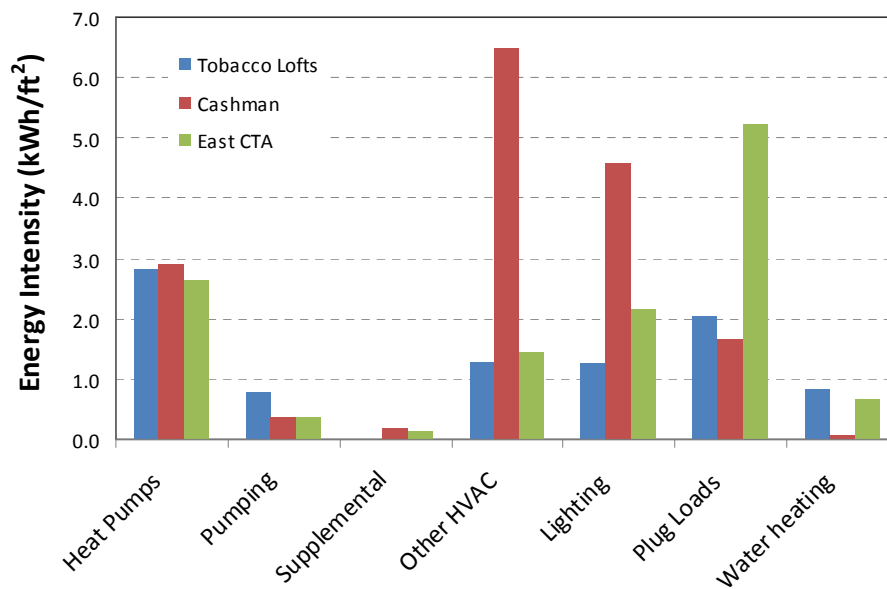

Figure 25. End use energy consumption of the buildings studied. Other HVAC is any equipment not on the HyGSHP system.

Figure 26 considers just the HyGSHP portion of this energy consumption, and is modified to be shown normalized to the total usage of each hybrid system. Note that although the supplemental equipment (boiler or tower) makes up a significant portion of the peak capacity of each system, it uses a relatively small portion of the energy consumption in the system.

²⁴ Calibrated energy modeling results were used to fill in gaps in data collection—for example, submetering was not done in all cases between water heating and other gas heating uses, so the model was used to differentiate those items. Energy consumption of devices on the HyGSHP loop was almost entirely derived from monitoring as opposed to modeling.

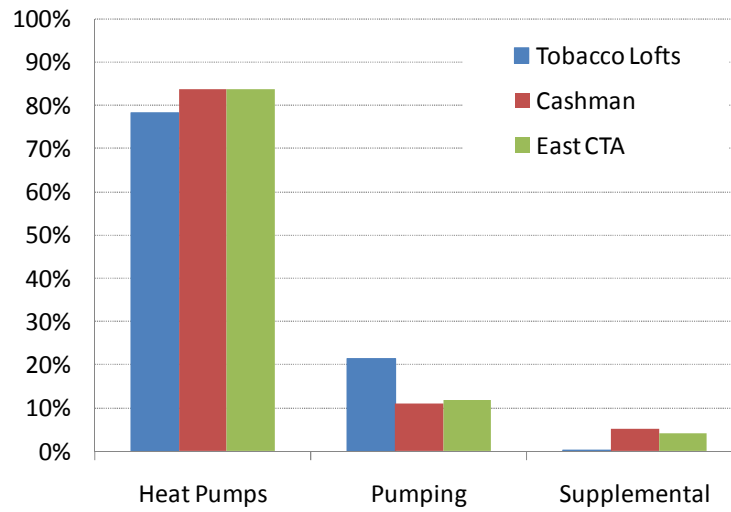

Figure 26. Energy end use consumption for just the equipment in the HyGSHP system.

The reason for this is clear when the distribution of building loads is considered. The loads—for the portions of the buildings served by the HyGSHPs—are plotted (as part load ratio) in Figure 27 in order of decreasing part load²⁵. As the load distribution shows, these buildings operate for much of their time at low loads. All three of the buildings spend less than 3% of their time in the top 40% of the load distribution. So although a large portion of the GHX has been replaced with *generally* less efficient equipment, the effect on total energy consumption is small. This notion could even be extended in some buildings to hybridize both the heating and cooling sides of the plant to further reduce cost.²⁶

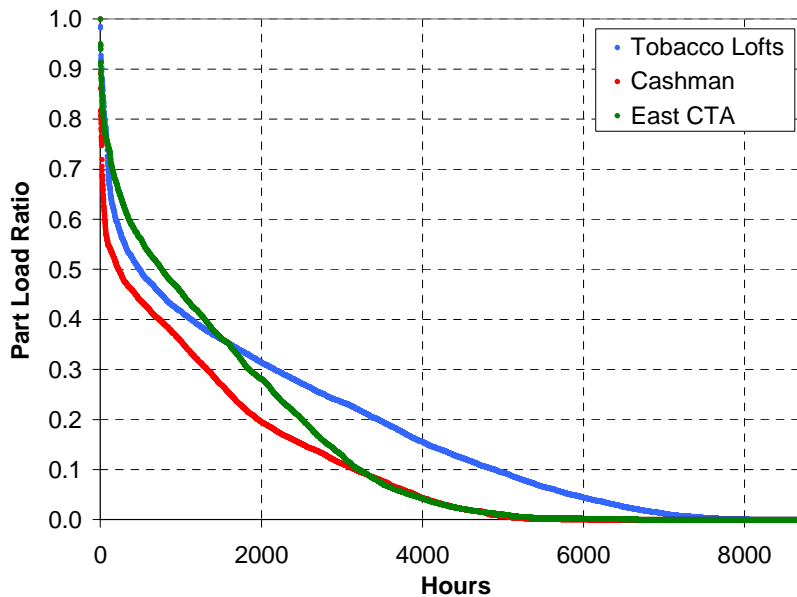

Figure 27. Load distribution for the three buildings.

²⁵ Part load ratio is simply equal to the current load on the system divided by the capacity of the system.

²⁶ That analysis is outside the scope of this study, but is a possible topic of future research.

Life Cycle Cost Comparison

A lot of different inputs are required to define the life-cycle cost assessment. Energy rates were based on actual utility rates paid by each facility, and costs were based on both actual costs at the site and nationwide cost research. Key economic parameters are briefly summarized in Table 13. A broader discussion of economic factors affecting hybrids, including cost research, is shown in the *Economic And Other Assumptions* section above. Note that we assumed the most relevant analysis for this study would be one that considers a hypothetical decision that needs to be made in the present—therefore our analyses use 2010-dollar costs and current economic data (as opposed to using costs at construction time).

	Value	Basis
General inflation	1.7%	Difference between 20 year treasury bills, inflation adjusted and not
Fuel inflation, electricity	1.42% - 1.52%	FEMP 10 year outlook, low end for WI site and high end for NV sites
Fuel inflation, natural gas	3.43% - 3.60%	FEMP 10 year outlook, low end for WI site and high end for NV sites
Total tax rate	35%	Federal business tax rate
Depreciation of plant equipment	5 years	IRS guidelines, MACRS
Discount rate	10% base*	
Life cycle cost timespan	20 years	

* Sensitivities to this value look at 5% as well

Table 13. Economic assumptions for life-cycle cost analysis.

These inputs are used in the validated models described in the *Modeling* section but with typical meteorological year (TMY) weather data. These models are coupled with an economic analysis tool that is constructed according to NIST Handbook 135 (Fuller, 1996), resulting in life-cycle costs and other related metrics.

Life cycle costs are meaningful in relative terms, when multiple options are compared with each other. Our initial cost analysis focuses on comparisons between the hybrid approach, a ground-source only system, and a conventional HVAC system. For East CTA and Cashman, the conventional HVAC system being considered is a VAV system with boiler and chiller. For Tobacco Lofts, the conventional HVAC system being considered is a water-source heat pump system (with boiler and tower, and no GHX). These represent three of the potential options actually considered by the building owners and designers for the buildings studied. More information regarding the assumptions for the conventional building/system models is given in the *Building Models* section (in general the baseline is based on ASHRAE 90.1-2004). For each building, the resource costs (energy and water cost per ft²) is plotted in Figure 28 for three system types.

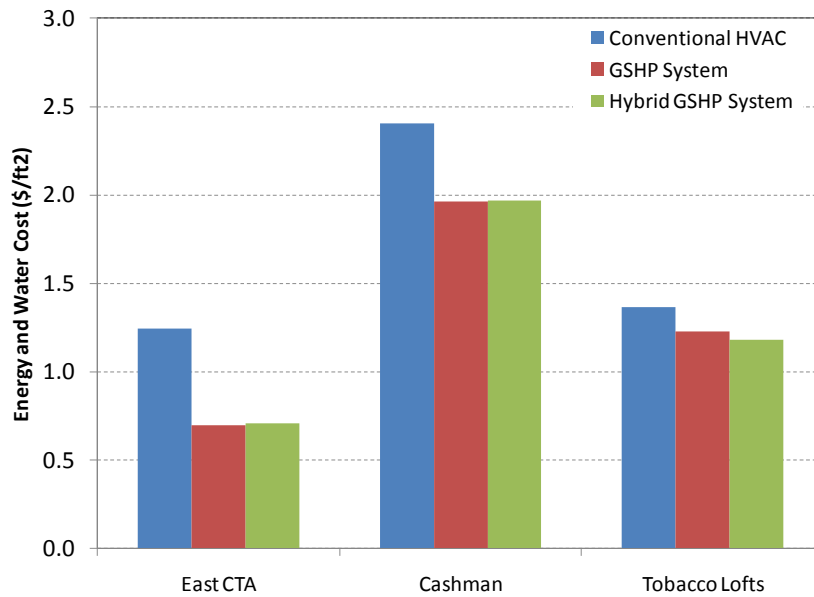

Figure 28. Energy and water cost of hybrid systems as compared with ground-source-only and conventional HVAC systems.

Figure 28 shows that both of these systems save a significant amount of operational cost as compared with conventional HVAC. But perhaps more importantly, the plot also shows that that energy (and water) costs of hybrid systems are quite similar to that of ground-source only systems in these three applications. Of course the savings comes at a higher installation cost for a ground-source system. This is demonstrated by the first costs of the HVAC system at East CTA (see Figure 29). Though the ground-source systems cost significantly more, the hybrid approach mitigates this increase, while maintaining much of the operational savings.

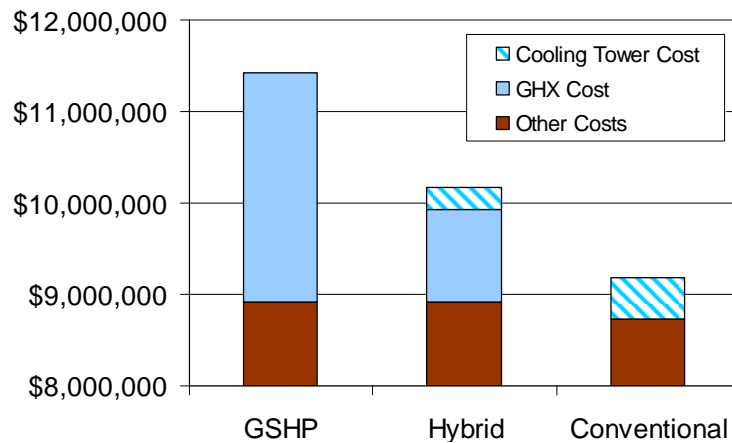

Figure 29. First costs by component for system options at East CTA.

We combined these operational and first costs, plus maintenance, tax effects, and salvage/replacement cost into a full 20-year total life cycle cost (LCC); this calculation is conceptually:

$$LCC = C_{First} + PV(C_{Energy}) + PV(C_{Maintenance} + C_{Water} + C_{replacement} - C_{TaxBenefits} - C_{Salvage})$$

Where each C is a separate cost, and PV is a present value function that accounts for discount rate, general inflation, and fuel inflation. The different costs are discussed in the *Economic And Other Assumptions* section. The resulting life cycle cost differences—life cycle savings, or LCS—for the two ground-source approaches are shown in Figure 30, relative to the conventional HVAC LCC.

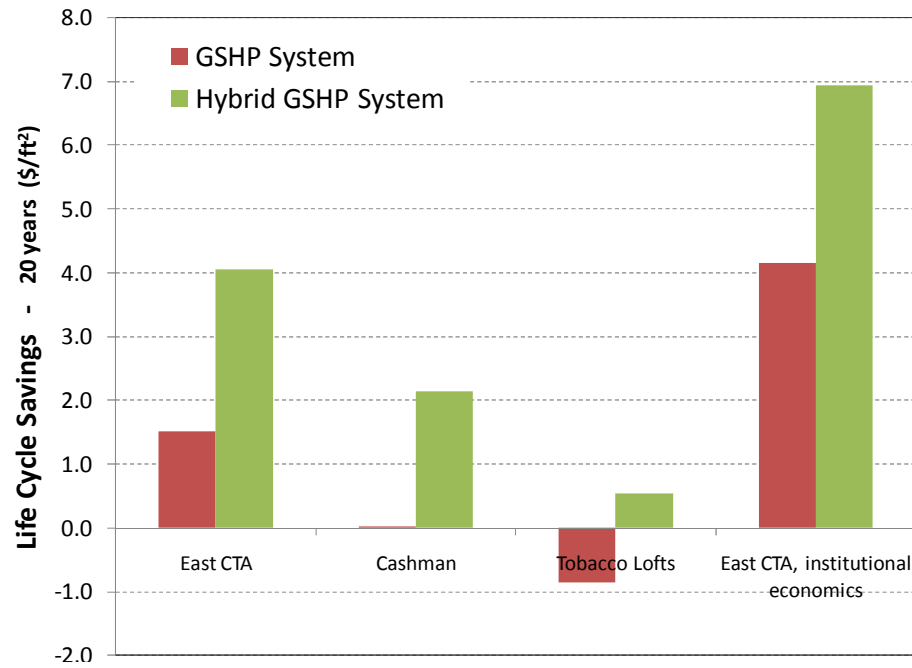

Figure 30. Life cycle savings of ground-source and hybrid systems, both vs. conventional HVAC. Note that the delta for GSHP system at Cashman is shown, but its value is so small as to be negligible.

The East CTA case labeled institutional economics is indicative of governments, schools, non-profit organizations, etc. (such as a school district as with East CTA) who do not pay income taxes and therefore do not share in the economic benefits available for those entities. These organizations also tend to use a lower discount rate, often tied to bonds that are used to fund projects; the rate assumed here is 5%.

In all four scenarios, the hybrid system has the best LCS of the three systems. The balance in the hybrid system between first cost and operational savings makes it an effective HVAC choice for all three facilities. In contrast, ground-source only systems do not show strong LCS for these three facilities, though they probably would in a more balanced climate.

Life cycle cost/savings is the preferred metric for determining the optimal economic choice when faced with different system options (Fuller, 1996). But LCS can be an abstract metric for some, as it is not comparable to a typical cash flow or other metric in operating a building or a business. Some simpler metrics can also be considered, though caution must be used as these metrics are not as definitive in this scenario as LCS is. One such simple metric is a rate of return, which can be compared to the rates of return available from other investments (in this case, per NIST guidelines, adjusted internal rate of return, or AIRR, is used). Rates of return are shown in Table 14 for 1) the investment in a hybrid system (as compared with a conventional system) and 2) the incremental investment in upgrading from the hybrid system to a fully ground-source system. The investment in a hybrid system is generally higher than the

rate realized by going fully ground-source —in the increment between hybrid and ground-source only, the highest rate of return between these three systems is only 5%.

	Cashman	East CTA	Tobacco Lofts
1) Hybrid GSHP instead of Conventional	10%	12%	9%
2) GSHP instead of Hybrid GSHP	5%	4%	1%

Table 14. Adjusted internal rate of return for two increments of investment in ground-source. First, the return for investing in a hybrid system vs. conventional HVAC. Secondly, the return for investing further in more GHX to the point of a fully ground-source system. Note that these numbers do not include a rate of return for investing in a ground-source-only system as compared to conventional HVAC.

Another, even simpler metric is simple payback. Simple payback is very commonly used to make decisions related to energy systems because it is so easy to use and sometimes results in an accurate ranking of options. But it should be considered with caution as it leaves out many effects including rate of return, inflation, fuel inflation, taxes, replacement costs, and more. Simple payback for the same two incremental decisions is shown in Table 15.

	Cashman	East CTA	Tobacco Lofts
1) Hybrid GSHP instead of Conventional	10.7	6.1	14.6
2) GSHP instead of Hybrid GSHP	93	117	Infinite

Table 15. Simple paybacks for two increments of investment in ground-source. First, the payback for investing in a hybrid system vs. conventional HVAC. Secondly, the payback for investing further in more GHX to the point of a fully ground-source system.

Economic Sensitivities

The economic viability of all GSHP systems is heavily influenced by both varying costs of natural gas and costs of GHX installation. We’ve therefore completed additional analysis to determine the sensitivity of our economic metrics to these parameters.

GAS COST SENSITIVITY

The price of natural gas, especially in recent years, is highly volatile. But the GSHP system economics are highly dependent on this cost since heat pumps essentially trade natural gas heating for electrically-driven heating. A sensitivity analysis was conducted to consider the effect of natural gas price on life cycle savings across all three buildings. Figure 31 shows the change in savings when natural gas price is 30% higher than the base case, and 30% lower than the base case. Increases in gas price create a modest increase in savings. Decreases in gas price create a substantial decrease in savings. The savings for choosing a hybrid system remain, but the average of these buildings is actually penalized for choosing ground-source only systems in that low gas-price environment.

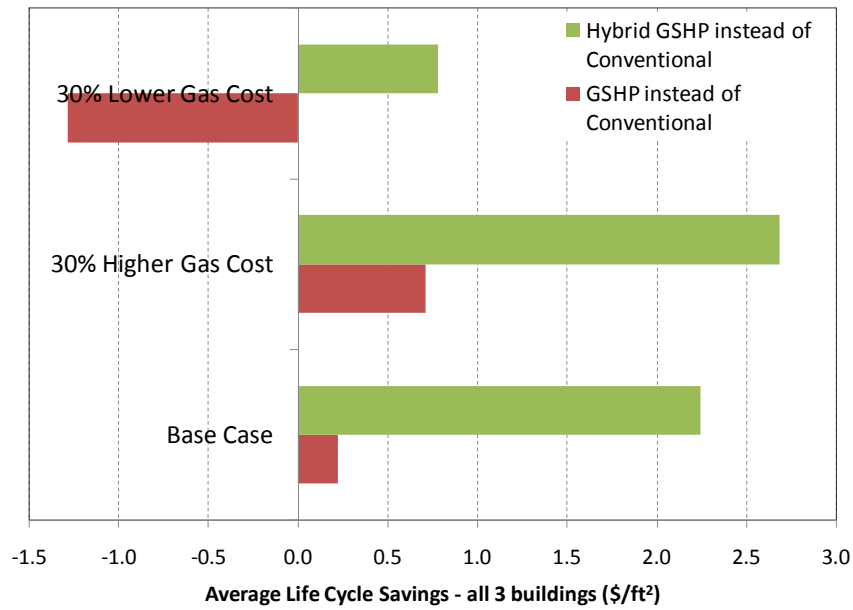

Figure 31. Average life cycle savings for a) HyGSHP and b) GSHP systems as compared with conventional HVAC systems. Results are shown for a range of different natural gas prices.

GHX COST SENSITIVITY

Another parameter likely to vary is the cost of the GHX. These costs fluctuate with regional expertise and supply/demand in what is still largely a niche industry. Sensitivity analyses were conducted based on the cost data collected both locally and nationally for these systems (see the *Installed Costs* section). For comparing among different GSHP and HyGSHP systems and size options, the 20th and 80th percentiles of GHX cost were used for low and high GHX cost, respectively. For comparing to conventional systems, the cost differences between the hybrid and conventional HVAC systems were varied by 30% above and 30% below the base case differential (recall that these differences are based on bids and estimates done during the actual project construction; see the *Installed Costs* section for more detail). Figure 32 demonstrates how life cycle savings changes with varying GHX cost. LCS for a GSHP system is highly dependent on GHX cost, whereas savings for a hybrid system is only modestly affected in each case.

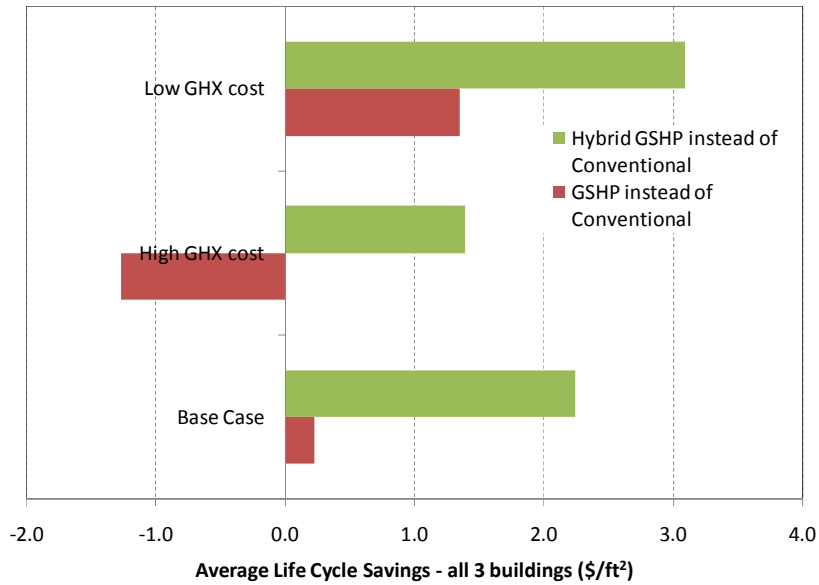

Figure 32. Average life cycle savings for a) HyGSHP and b) GSHP systems as compared with conventional HVAC systems. Results are shown for a range of different GHX costs.

CLIMATE SENSITIVITY

Finally, the success of hybrid systems in these cases is of course heavily dependent on the climate in which the buildings are installed. In this case the sensitivity analysis uses just Cashman, which is installed in the hot, dry climate of Henderson, Nevada. Two separate sensitivity analyses were considered for this project. First, the building was relocated to New Orleans, Louisiana, where it is hot but humid; therefore the effectiveness of the cooling tower, especially during the day, is lessened. Secondly, the building was relocated to Washington, D.C., where the climate is much more moderate. In this climate the building is neither cooling nor heating dominated (the ratio of annual cooling to heating is near one; see Table 16).

	Las Vegas, NV	New Orleans, LA	Washington, DC
Ratio: Annual Cooling / Annual Heating	3.5	5.0	0.7
Ratio: Peak Cooling / Peak Heating	0.7	0.7	0.4

Table 16. The ratio of cooling to heating loads for Cashman, as placed in climates representative of three different locations.

In all cases the equipment sizes were re-optimized for the specific climate. The life cycle savings for Cashman GSHP systems in different climates is shown in Figure 33. Savings for New Orleans is very similar to the savings shown in Las Vegas. But in the moderate climate of Washington, DC, the hybrid case has essentially the same benefit as a ground-source only system. In a building with well-balanced loads such as this it is likely not worth the extra complexity to choose a hybrid system over a GSHP system—especially if the staff operating the system are not highly technical. Note that these results are as much due to the Cashman building type as they are to the climate. To reach such a balance in loads, certain building types may need to be located even further north (and in other cases, less so).

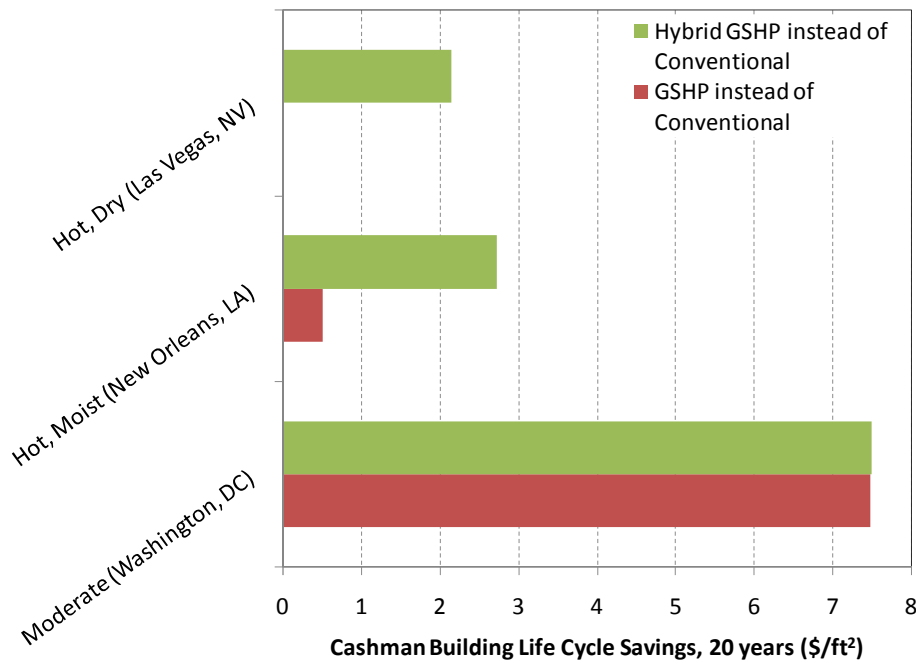

Figure 33. Life cycle savings for the Cashman building in three different climates, for both a) HyGSHP and b) GSHP systems as compared with conventional HVAC systems.

EMISSIONS ANALYSIS OF HYBRID APPROACH

Increasingly, environmental impacts are considered as closely as economic impacts when making building design decisions. Owners and builders are recognizing that buildings use a large portion of the primary energy in the United States, and account for an even larger portion of air emissions (39% of the carbon dioxide emissions, in the United States, EIA 2008). One of the largest environmental impacts a building can make is through emission of carbon dioxide and other global warming causing gases (USGBC, 2009). Studying the relative impact of hybrid systems on carbon dioxide emissions therefore gives us some sense (though certainly not a complete picture) of the relative environmental impact of these systems as compared to other options. Note that determining relative environmental impact with a heat pump system is not as clear as simply looking at primary energy consumption, because many of the tradeoffs in this analysis involve changes in both natural gas and electricity, which have very different emissions factors.

It is therefore useful to consider the relative emissions of a hybrid system versus the other system options. We began by researching emissions factors to use in the calculation. Emissions factors vary by region due to differences in electric generation fuel mix, and other electricity supply-side factors. Ideally, emission factors for electricity are developed based on the entire grid where the electricity is used (so state-specific numbers are not useful) and are also based on marginal generation (as prescribed by GHGPI, 2009). The emission factors found for use in this study are shown in Table 17.

		Electricity Emissions (lbs/kWh)	Gas Emissions (lbs/therm)
Tobacco Lofts	CO ₂	1.7	11.8
	NO _x	2.9E-03	9.8E-03
	SO _x	2.7E-03	5.9E-05
	Mercury	1.5E-11	2.6E-08
Cashman and East CTA	CO ₂	1.3	11.8
	NO _x	1.1E-03	9.8E-03
	SO _x	6.8E-04	5.9E-05
	Mercury	9.5E-09	2.6E-08
US Average	CO ₂	1.7	11.8
	NO _x	2.3E-03	9.8E-03
	SO _x	6.5E-03	5.9E-05
	Mercury	2.6E-08	2.6E-08

Table 17. Emission factors for the regions considered in this study, along with the national average. Wisconsin factors are based on (PA, 2008). Nevada factors are based on (Leonardo, 2009).

We used these factors to compare emissions across the same system options that were compared in the economic analysis. Emissions savings for carbon dioxide, the primary greenhouse gas, are shown in Figure 34. Both hybrid and ground-source-only systems result in a similarly high level of carbon dioxide savings in these three installations.

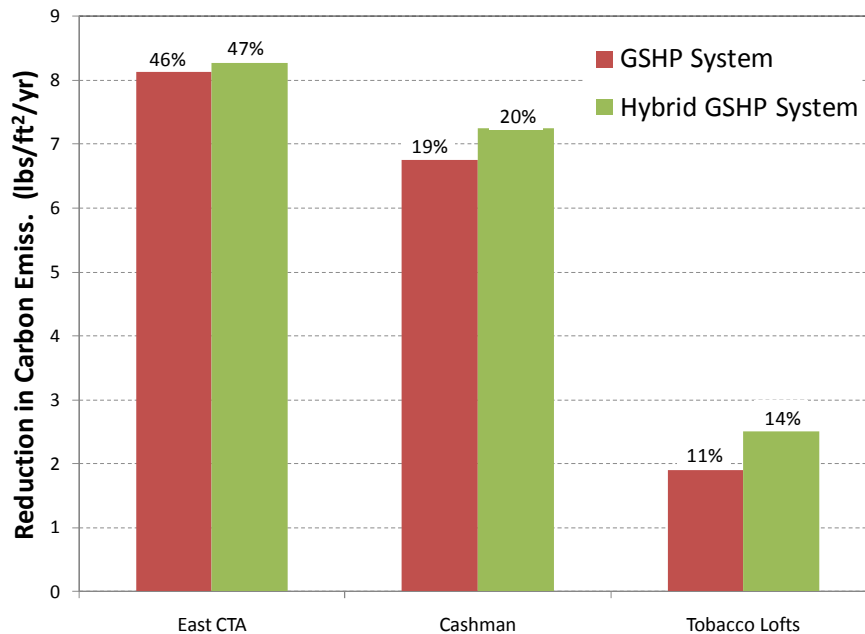

Figure 34. Carbon dioxide emission savings (per year) for each of the sites for both hybrid GSHP systems and GSHP systems, as compared with conventional HVAC.

Other emissions of concern include NO_x, which causes several problems including harmful ground-level ozone, SO₂, which causes dangers including acid rain, and mercury, which is a direct danger to humans via bioaccumulation. For these three pollutants, savings for each site followed trends similar to those for CO₂ (since electricity savings was by a large margin the primary driver behind all four emissions savings rates). The average emission rate for each pollutant across all three sites is summarized in Figure 35.

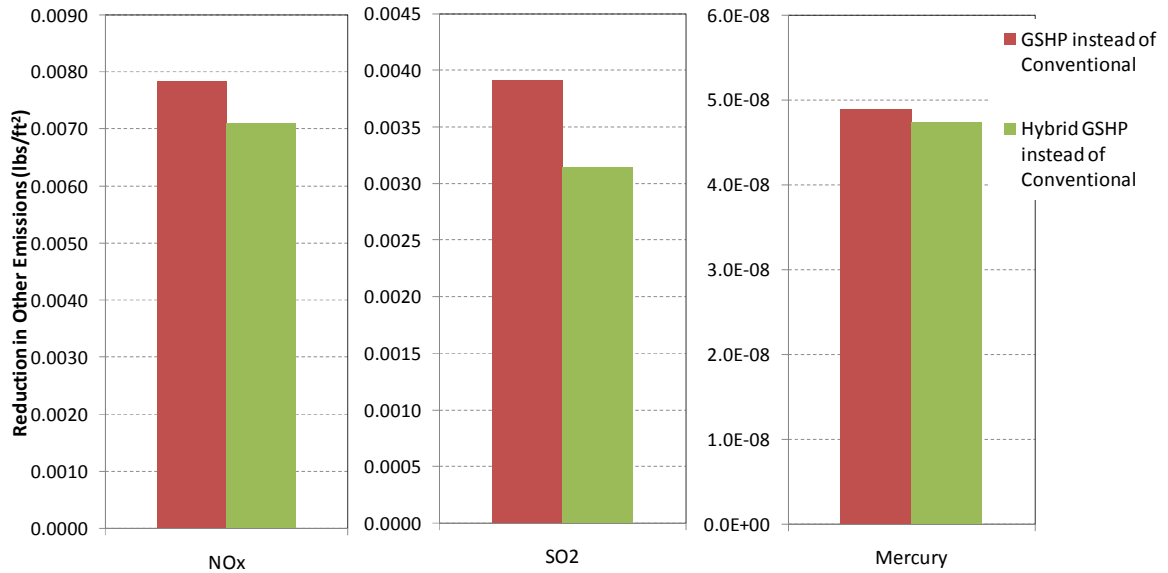

Figure 35. Average emission savings (per year) for across all three sites for both hybrid GSHP systems and GSHP systems, as compared with conventional HVAC.

In general, for these three sites, there is significant emissions savings in adopting GSHP systems, for most major pollutants²⁷, and utilizing the hybrid approach at these sites results in a similar emissions reduction to ground-source-only systems.

²⁷ One omission is particulates (e.g. PM₁₀), which was not included here due to a lack of grid-wide particulate emissions data for the sites studied. Since particulate emissions from natural gas are generally minimal, the emissions for particulates would generally follow the same trend as the other pollutants.

HYGCHP TOOL

The results of three case studies, as comprehensive as they may be, cannot be applied universally. Therefore our model will be made freely available to the engineering community, in a distributable format with a user interface that can be manipulated by someone without the knowledge or access to the TRNSYS software used to create it. This distributable version, called HyGCHP²⁸, is fundamentally consistent with the models validated and used for the three buildings that we studied in this project, including use of all the same component models (heat pumps, cooling towers, GHX, etc.). The system configurations have however been generalized to make them applicable for a wider range of building projects. Building design professionals can use the software to analyze a variety of heat pump system strategies for their buildings. Firstly the program includes a simple, ground-source only system allowing novice users to harness the TRNSYS DST ground heat exchanger model in a straightforward manner. Additionally, the program includes four different cooling-dominated hybrid ground-source systems: cooling tower either upstream or downstream of GHX, dry fluid cooler upstream of GHX, and cooling tower with entering temperature control. It also includes a heating dominated hybrid configuration with a boiler downstream of the GHX. And finally, it allows the user to remove the GHX and model some conventional water source heat pump systems.

Though the software is simple to use without energy modeling experience, it does require hourly loads as an input (the package does not include building load modeling capability, as there are a wide variety of building energy modeling tools already proven and available). Though many ground-source heat pump design and analysis software packages require only peak and annual loads, there is already some movement in the industry towards using hourly loads, which have the potential to increase accuracy (though the quality of the load estimate is still paramount over the time interval). And hourly loads are becoming more readily available as building energy models are increasingly used as an integrated part of the building design process—commonly used tools such as eQUEST and TRACE are capable of producing hourly loads. Once loads are input, the user has the ability to modify all system parameters from heat pump efficiency to the conductivity of the GHX's grout, and run a simulation to determine the resulting system temperatures, efficiencies, energy usage, and financial impacts (including energy cost and total life cycle cost). These results can be used for comparing merits of different designs. An included optimization algorithm can be used to find such things as optimal equipment size, based on LCC.

The HyGCHP tool is expected to be helpful for analysis of HyGSHP system options throughout the planning and design process for new buildings and renovations, from a simple feasibility study early in design to a more refined design analysis. It can supplement use of existing ground heat exchanger sizing software such as GCHPCalc, Ground Loop Design, and GHLEPRO. Where these tools have more simplified methods for considering hybrid options (and doing economic calculations) the HyGCHP program can be used to study the effect of hybrid designs in more depth. The tool is also meant to supplement existing energy modeling tools. Commonly used energy modeling tools have some significant limitations in their ability to model HyGSHP systems; this tool can handle configurations that they lack. And some may simply be interested in the ability to utilize the DST GHX model in relatively straightforward manner. HyGCHP is available for download on both the Energy Center (<http://www.ecw.org/hybrid>) and UW Solar Energy Lab (<http://sel.me.wisc.edu/>) websites.

²⁸ A distributable of that model version was also released through ASHRAE as a beta test. The distributable from the current project represents a significant improvement to its predecessor.

CONCLUSIONS AND FUTURE WORK

Our study of these three HyGSHP has demonstrated that if implemented correctly, hybrid systems can be a cost effective method of incorporating a ground-source system into a building system (at least for buildings similar to those studied here). Generally hybrids were more cost effective than ground-source-only as well as conventional systems, and in some cases actually saved more energy (and emissions) than the purely ground-source approach. There seem to be a few areas that designers and operators of these systems need to focus on to improve operation: proper equipment sizing, design and operation of part load pumping strategies, and tweaking of equipment setpoints after installation. Tools that allow personnel to analyze these issues are beginning to become more available; we validated one such tool, HyGCHP, in this study but other ground-source tools are expanding to cover hybrids in more depth as well.

These lessons and tools can hopefully be used to get owners who would normally not consider a ground-source system to reconsider; the savings are certainly worth a pause in any systems selection discussion. System complexity may still be an issue for some. For example, depending on staffing, hybrids may not be the best choice for facilities without either an on-site HVAC facility manager or a good service relationship with a local mechanical firm. But in general, these systems should be implementable on most buildings. Though they can seem complex, it can be demonstrated to owners and facility personnel that the components of these systems (GHXs, towers, boilers) are far from new. And the combination of components only requires one or two additional controls be implemented. Those control items just need to be well thought through both in design and post-occupancy, so that the system operates to its potential.

FUTURE WORK

There will continue to be a need for studying HyGSHP systems in the coming years. Improving the tools to design hybrid systems is going to be a challenge for ground-source design software and publication authors to overcome. And if these tools are to be improved to allow consideration of 8760 loads for sizing and control design, the links between hourly building simulation models (such as eQUEST, TRACE, and EnergyPlus) and ground-source design tools will need to be made tighter. Tools that allow for continued optimization of the system after occupancy are only beginning to be developed; improvement to these could be increasingly important as systems get more complex. For the tool validated in this study, computational speed is the primary area for improvement (the amount of time needed for the TRNSYS GHX to run is longer than many engineers will be willing to wait).

Though our study, as well as many before it, have considered both heating and cooling dominated hybrid systems, we did not consider the cost-effectiveness of a double hybrid, in which both a cooling tower (or similar device) and boiler are connected to a GHX. For more balanced buildings (such as a high performance office building in Chicago), a hybrid is not needed due to load imbalance, but a double-hybrid could be cost-effective to deal with the small amount of high part load ratio that we found in analyzing these buildings (as evidenced in Figure 27).

When it comes to controls, one area in which the University of Wisconsin is going to continue researching is the study of supplemental cooling control in hybrid systems, specifically the idea of precooling. Only a few studies have investigated this idea in any depth, and there are a wide range of control strategies to consider. Options range from seasonal precooling (running a tower during heating

season) to the nighttime precooling discussed here, to a timing-neutral approach like forecast control (suggested by Xu, 2007).

And finally, there is a need for better understanding of the long term temperature impacts of load imbalance on the ground. We suggest in this report that it might not be cost effective to use hybrid systems to fully balance the load on the ground. With this strategy it becomes just as important in hybrids to consider long-term temperature penalties as it is in a ground-source-only systems. Several models have been proposed for calculating this long-term effect, but there is considerable disagreement between the methods, and a lack of long-term operational data to enlighten the discussion.

REFERENCES

- “2007 ASHRAE Handbook: HVAC Applications”. 2007. American Society of Heating, Refrigeration, and Air-Conditioning Engineers (ASHRAE).
- Andrushuk, R. 2008. “Monitoring Field Performance of Residential Geothermal Heat Pumps”, presentation on November 18, 2008. Manitoba Hydro.
- Chiasson, A., and C. Yavuzturk. 2003. “Assessment of the Viability of Hybrid Geothermal Heat Pump Systems with Solar Thermal Collectors”, *ASHRAE Transactions 2003*. ASHRAE.
- Chiasson, A., and C. Yavuzturk. 2009. “A Design Tool for Hybrid Geothermal Heat Pump Systems in Cooling Dominated Buildings”, *ASHRAE Transactions 2009*. ASHRAE.
- Chiasson, A.D. 2009. “A Design Tool for Hybrid Geothermal Heat Pump Systems in Heating-Dominated Buildings”. *ASHRAE Transactions 2009*. ASHRAE.
- Cui, P., H. Yang, J. Spitler, Z. Fang. 2008. “Simulation of hybrid ground-coupled heat pump with domestic hot water heating systems using HVACSIM+”, *Energy and Buildings*, Volume 40, Issue 9.
- “EIA Annual Energy Outlook”. 2008. Environmental Information Administration.
- Fuller, S, and S. Peterson. 1996. “NIST Handbook 135: Life Cycle Costing Manual for the Federal Energy Management Program”. National Institute of Standards and Technology.
- Gentry, J. et al. 2006. “Simulation of Hybrid Ground Source Heat Pump Systems and Experimental Validation”. *International Conference on System Simulation in Buildings*.
- Greenhouse Gas Protocol Initiative. Accessed March 2009. <http://www.ghgprotocol.org/>
- Hackel, S., S.A. Klein, G.F. Nellis. 2009a. “Optimization of Cooling-Dominated Hybrid Ground-Coupled Heat Pump Systems”, *ASHRAE Transactions 2009*. ASHRAE.
- Hackel, S. 2009b. *Ten-year Update: Emissions and Economic Analysis of Geothermal Heat Pumps in Wisconsin*. Energy Center of Wisconsin.
- Hellström, G. 1989. “Duct Ground Heat Storage Model: Manual for Computer Code”. Department of Mathematical Physics, University of Lund, Sweden.
- Introduction to LEED 2009*. 2009. United States Green Building Council.
- Jinggang, Wang, Gao Xiaoxia, Yin Zhenjiang, and Li Fang. 2009. “Study of Operating Control Strategies for Hybrid Ground Source Heat Pump System with Supplemental Cooling Tower”, *2009 IITA International Conference on Services Science, Management and Engineering*, IEEE.
- Kavanaugh, S., K. Rafferty. 1997. “Design of Geothermal Systems for Commercial and Institutional Buildings.” ASHRAE.

Kavanaugh, S. 1998. "A Design Method for Hybrid Ground-Source Heat Pumps", *ASHRAE Transactions* 1998. ASHRAE.

Klein et al. 2006. "TRNSYS, A Transient System Simulation Program, User's Manual, Version 16". Solar Energy Laboratory, University of Wisconsin-Madison.

Leonardo Academy. 2009. "Emissions Factors and Energy Prices for Leonardo Academy's Cleaner and Greener Program, prepared for the Multiple Pollutant Emission Reduction Reporting System." Leonardo Academy.

Michaels Engineering. 2008. Performance, Emissions, *Economic Analysis of Minnesota Geothermal Heat Pumps*, Michaels Report #MJ807AAN. Minnesota Department of Commerce.

PA Knowledge Limited. 2008. "Quantifying Environmental Benefits of Focus on Energy: Emission-rate Estimates 2002 to 2006." PA Knowledge Limited.

Pardo, N., Á. Montero, J. Martos, and J.F. Urchueguía. 2010. "Optimization of hybrid – ground coupled and air source – heat pump systems in combination with thermal storage", *Applied Thermal Engineering* 30, no. 8-9 (June).

Pertzborn, A., S. Hackel, G. Nellis, S. Klein. 2011. "Experimental Validation of the Ground Heat Exchanger in a Hybrid Ground Source Heat Pump," submitted to *HVAC&R Research*, May 19, 2011. Pending approval.

Phillippe, M., M. Bernier, and D. Marchio. 2010. "Sizing Calculation Spreadsheet Vertical Geothermal Borefields", *ASHRAE Journal*, July 2010. ASHRAE.

Puttagunta, S., R. Aldrich, D. Owens, and P. Mantha. 2010. "Residential Ground-Source Heat Pumps: In-Field System Performance and Energy Modeling", *Geothermal Research Council Transactions 2010*, Vol. 34. Geothermal Research Council.

Shonder, J. A., Baxter, V., Thornton, J., & Hughes, P. 1999. "A new comparison of vertical ground heat exchanger design methods for residential applications", *ASHRAE Transactions* 1999. ASHRAE.

Thornton, J. 2005. "Hybrid Geothermal Heat Pumps at Fort Polk, Louisiana, Final Report to Oak Ridge National Laboratory." Thermal Energy Systems Specialists (TESS).

Thornton, J. W., McDowell, T. P., & Hughes, P. J. 1997. "Comparison of Practical Vertical Ground Heat Exchanger Sizing Methods to a Fort Polk Data/Model Benchmark", *ASHRAE Transactions* 1997, 104(1). ASHRAE.

Wetter, M. 2009. *GENOPT 2.0 Generic Optimization Program*, Accessed August 2010. <http://gundog.lbl.gov/GO/>.

Xu, Xiaowei. 2007. "Simulation and Optimal Control of Hybrid Ground Source Heat Pump Systems." PhD Thesis. Oklahoma State University.

Yavuzturk, C. et al. 2009. "Simulation Model for Ground Loop Heat Exchangers", *ASHRAE Transactions 2009*. ASHRAE.

Yavuzturk, C. and J.D. Spitler. 2000. "Comparative Study to Investigate Operating and Control Strategies for Hybrid Ground Source Heat Pump Systems Using a Short Timestep Simulation Model," *ASHRAE Transactions 2000*. ASHRAE.

Zweifel G., V. Dorer, M. Koschenz, and A. Weber. 1995. "Building Energy and System Simulation Programs: Model Development, Coupling and Integration", *1995 International Building Performance Simulation Association Conference Proceedings*. IBPSA.

APPENDICES

APPENDIX A. DATA COLLECTED











Data collected from each of the three sites in this study has been compiled for use by others who wish to study these systems for further research, compare system operating points to their own buildings, or simply look at the data that our calculations were based on. The full set of data from all three buildings is available in a single download, in either Excel spreadsheet format or comma-separated format. This data can be found at www.ecw.org/hybrid.

Units for each data point are given, as is a description of whether the data is actually measured, directly calculated from measured, or derived in some other manner. The following files can be found in the download:

Spreadsheet (.xlsx) download:

 Data - Cashman.xlsx	13,916 KB	Microsoft Office Excel 2007 Workbook
 Data - East CTA.xlsx	5,101 KB	Microsoft Office Excel 2007 Workbook
 Data - Tobacco Lofts.xlsx	22,705 KB	Microsoft Office Excel 2007 Workbook

Comma-separated (.csv) download:

 Data - Cashman, Calculated.csv	2,387 KB	Microsoft Office Excel Comma Separated Values File
 Data - Cashman, Measured.csv	9,888 KB	Microsoft Office Excel Comma Separated Values File
 Data - East CTA, Measured (Status).csv	2,870 KB	Microsoft Office Excel Comma Separated Values File
 Data - East CTA, Measured (Streaming).csv	3,109 KB	Microsoft Office Excel Comma Separated Values File
 Data - Tobacco Lofts, Measured (Plant).csv	10,502 KB	Microsoft Office Excel Comma Separated Values File
 Data - Tobacco Lofts, Measured (Unit B).csv	285 KB	Microsoft Office Excel Comma Separated Values File
 Data - Tobacco Lofts, Measured (Unit A).csv	539 KB	Microsoft Office Excel Comma Separated Values File
 Data - Tobacco Lofts, Measured (Unit C).csv	550 KB	Microsoft Office Excel Comma Separated Values File
 Data - Tobacco Lofts, Measured (Unit D).csv	500 KB	Microsoft Office Excel Comma Separated Values File
 Data - Tobacco Lofts, Measured (Unit E).csv	476 KB	Microsoft Office Excel Comma Separated Values File
 Data - Tobacco Lofts, Measured (Unit F).csv	507 KB	Microsoft Office Excel Comma Separated Values File

Note that data from East CTA is broken into two categories: status data is simply a series of timestamps establishing the timing for various pieces of equipment turning on/off, while streaming data is a typical data point collected once every 15 or 60 minutes. Data at Tobacco Lofts is also broken into two categories: plant data is collected in the central mechanical room of the apartment complex (and so contains data for the boiler, pumps, etc.), while data for the six living units (10% of the total units) that were studied is given on separate documents divided by living unit (unit names do not reflect the actual name of the living unit to protect privacy).

APPENDIX B. HYGSHP FACT SHEET

As a summary of this report, for the purpose of more general distribution, we assembled a brief fact sheet. It is reproduced on the next two pages.

Hybrid ground source heat pump systems have the potential to make ground source heat pump systems (GSHP) more cost effective.

Though GSHP systems can significantly reduce energy consumption in commercial buildings, the high first cost of installing the ground heat exchanger (GHX) can be a barrier. A hybrid system uses conventional technology such as a cooling tower or boiler (Figure 1) to meet a portion of the peak heating or cooling load. This innovation allows you to install a smaller, less expensive GHX.

Comparing hybrids, GSHPs and conventional HVAC

In a study sponsored by the U.S. Department of Energy, the Energy Center analyzed performance and economic data from three hybrid installations to:

- disseminate lessons learned,
- validate models for others to use in analyzing hybrid systems, and
- assess the economic and

environmental effectiveness of hybrids in comparison to GSHPs and conventional HVAC.

Our analysis found that all three installations were economically cost effective. The average rate of return for investing in hybrids in these three cases was 10%. If they had invested in additional GHX to go to a full GSHP system, the rate of return on the *additional* investment would have averaged just 3% (Figure 2).

Additionally, choosing a hybrid does not sacrifice environmental benefits (including carbon savings) because, in general, the supplemental equipment operates very infrequently due to the typical part-load operation of these commercial buildings.

Lessons learned

By monitoring and analyzing installed hybrid ground source heat pump systems, the Energy Center was able to add to the body of knowledge on

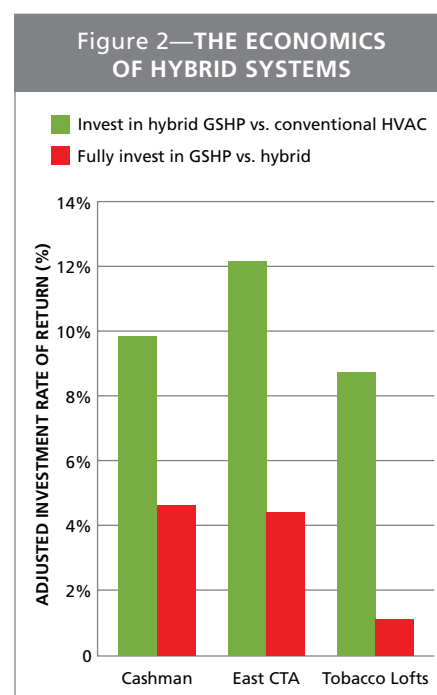
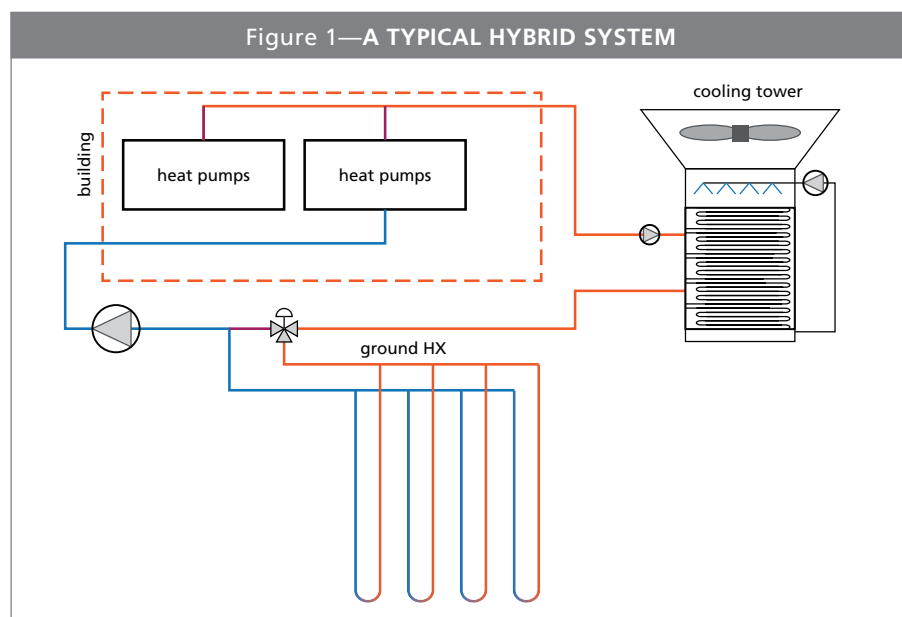

the design of these systems. Some of the lessons learned from study of these buildings include:

Component sizing in a hybrid system is extremely important—do not oversize the load that drives the GHX size. Use a sizing algorithm that optimizes the tower or boiler (see references and software options below; use hourly—8760—loads as inputs if at all possible).

Pumping uses a lot of energy in a hybrid system. Minimize pump sizes and focus on part-load performance. For central pumping include a part-load pump of a smaller size (~50%). Consider using smaller individual pumps for “rogue” zones. Choose variable speed wherever applicable with a well-positioned dP sensor that is adjusted downward (post-occupancy) to allow for the lowest speed possible.

CASE STUDY: EAST CTA



Courtesy of SH Architecture

East Career and Technical Academy is a vocational high school in Las Vegas, Nevada. Individual, closet-installed heat pumps serve each space and are tied back to the mechanical room via one large variable flow secondary loop. These secondary building loops are connected to a primary loop, which has a 168,000 ft GHX and two, multi-speed cooling towers (167 tons each) attached. East CTA is a heavily cooling-dominated building and investing in a full ground-source system would have been cost-prohibitive. By investing in the hybrid system, the district is saving approximately \$0.50/ft² in operating costs annually—only a few cents less than a full ground-source system. And the district realized first cost savings of \$1 million by going hybrid.

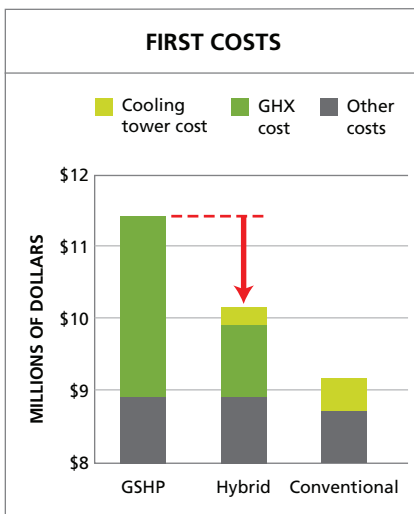

Cooling towers or fluid coolers should be variable speed (if multiple towers, ramp up/down together, not staged), and ramp down quickly enough to shut off shortly after substantial cooling. Tweaking the control setpoints after occupancy can ensure efficient operation.

If using nighttime precooling with a cooling tower, operate it for a short period of time (a few hours), right before morning startup, and at a lower fan

speed. Precooling does not have to be used to balance load on the ground.

The loop should be able to bypass the GHX. Set a reasonably wide deadband (20–30°F) in which the GHX is not used; with GHX in cooling-dominated systems coming on only ~10°F below the setpoint of the cooling tower.

Boilers should be placed downstream of GHXs and controlled to a setpoint

5–10°F below the GHX. Condensing boilers work very well in these systems.

Heat pump operation—use optimal or staged startup to avoid large peaks. Ensure proper return air paths and maintenance accessibility to the units, and partially economize using outdoor air if possible.



FOR MORE INFORMATION

Contact Scott Hackel at 608.238.8276 x129 or shackel@ecw.org

To read the full study, see: www.ecw.org/hybrid

Resources

Software tools

HyGCHP—free version of the model from this study, allows for comparison of a variety of hybrid and conventional design approaches.

EnergyPlus—free software from the U.S. Department of Energy for full building modeling, including hybrid capability.

TRNSYS—full building thermal modeling, with the capability of studying any hybrid system imaginable.

Sizing tools—ground-source sizing tools like GLD 2010, GCHPCalc and GLHEPro have some very basic hybrid sizing capability.

Design references

Basic design information: *A Design Method for Hybrid Ground-Source Heat Pumps* by Kavanaugh (ASHRAE Transactions 1998); other work by Kavanaugh and Rafferty.

Simulation and Optimal Control of Hybrid Ground Source Heat Pump Systems by Xu (Ph.D. Thesis, 2007); www.hvac.okstate.edu/theses.html

Optimal hybrid sizing; some sample control sequences: <http://sel.me.wisc.edu/publications-theses.shtml> (thesis by Hackel)